



Diamond Drilling Technology



CORE DRILLING MACHINE H-250

- compact, light construction made of aluminium
- max. lifting 650 mm, max. drill-Ø 250 mm
- integrated pivot function in stand foot 0-45°
- fixing with set of dowels or vacuum
- carriage with large, adjustable sliding shoe made of plastics
- standard support with ergonomic carrying handle
- feed via toothed rack
- large star handle, to be mounted on both sides
- tool-free change of drill motor by mounting plate type „dove tail“
- weight of drill column approx. 17 kg



H-250 with mounting plate type C and drill motor C-BMS-200/3



H-250 with mounting plate type B and drill motor DK-17-EL

Max. drill-Ø for drill column with different drill motors

drill motor		max.drill - Ø with	
type	max. Bohr-Ø Motor - mm -	mounting plate type B	mounting plate type C
C-BMH-152/3	152 (250*)	152 (250*)	-
C-BMS-200/3	200	-	200
DK-17 EL	160 (200*)	160 (200*)	-
DK-32-EL C	350	-	250

Attention! Max. drill-Ø with vacuum 160 mm

for drill diameter up to 250 mm

H-250		
item		description
1	H-250	drill column with carriage and aluminium stand foot, drilling stroke 650 mm
2	C-BMH-152/3	electric motor, 2,0 kW, 230 V, drill-Ø 20-152/250*
3	C-BMS-200/3	electric motor, 2,2 kW, 230 V, drill-Ø 35-200/250*
4	DK-17-EL	electric motor, 2,0 kW, 230 V, drill-Ø 20-160/200*
5	DK-32-EL C	electric motor, 3,0 kW, 230 V, drill-Ø 50-350
6	---	motor mounting plate type B for electric motors with 60 mm adaptor collar
7	---	motor mounting plate type C for electric motors
8	---	dowel set for fixing the drill column (refer to page 24)
9	---	quick-tensioning column for bracing
10	---	set of wheels universal
11	---	vacuum set for H-250
12	VPU-206	vacuum pump, 230 V, 100 l/min
13	---	pipe drilling foot plate
14	---	1 set = 2 pcs. tension bands with ratchet, 4 m long; for pipe drilling foot plate
15	WSR	water collecting ring for drill-Ø 161 mm
16	---	seal disc for water collecting ring in various diametres

* in abrasive material



H-250 with mounting plate type C and drill motor DK-32-EL C

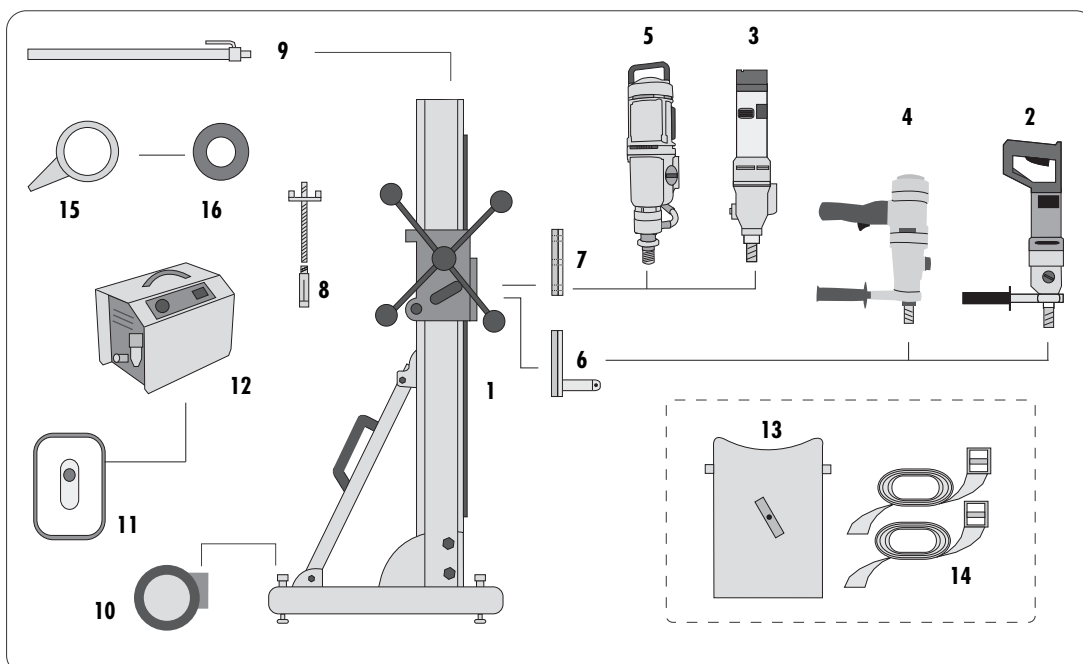

CORE DRILLING MACHINE P-1500

- torsion-resistant stainless steel drill column 45 x 45 mm
- compact, highly solid carriage made of aluminium
- carriage can be removed from the column
- carriage guidance via 8 heavy-duty, sealed special ball bearings (each 4 front and rear), adjustable via eccentric bearing shafts
- lateral carriage guidance via large-sized and easily adjustable brass contact surfaces
- ergonomic carrying handle near to balance point
- mounting of drill motor by motor mounting plate or directly to carriage (screws and feather key for direct mounting stored in carriage)
- weight of drill column only approx. 13 kg



P-1500 with mounting plate B and drill motor C-BMH-152/3



P-1500 with mounting plate B and drill motor DK-17-EL



carriage for mounting of motor with motor mounting plate type „dove tail“



carriage for direct mounting of motor

Simple handling for horizontal drillings



fixing the dowel foot with the column to the wall



mounting the carriage with drill motor and drill bit from rear to the column



mounting a securing sheet against unintentional removal of the carriage

for drill diameter up to 150/200* mm

* with mounted telescopic support

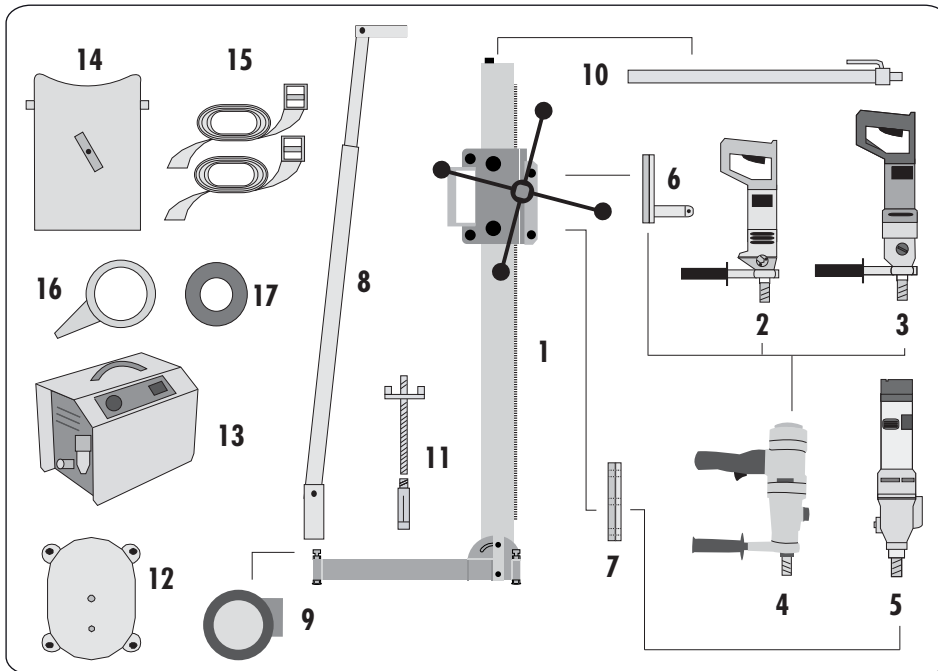

drill motor		max. drill-Ø with	
type	max. drill-Ø motor - mm -	mounting plate type B	mounting plate type C
Talpa 1800-102-41 EL	102	102	-
C-BMH-152/3	152 (250*)	152 (200*)	-
DK-17 EL	160 (200*)	160 (200*)	-
C-BMS-200/3	200	-	200

max. drill-Ø for drill column with different drill motors

P-1500		
item		description
1	P-1500	drill column with carriage, pivoting in steel dowel foot, drilling stroke 650 mm
2	Talpa 1800-102-41 EL	electric motor, 1,8 kW, 230 V, Bohr-Ø 60-102/162* mm
3	C-BMH-152/3	electric motor, 2,0 kW, 230 V, Bohr-Ø 20-152/250*
4	DK-17-EL	electric motor, 2,0 kW, 230 V, Bohr-Ø 20-160/200* mm
5	C-BMS-200/3	electric motor, 2,2 kW, 230 V, Bohr-Ø 35-200/250*
6	---	motor mounting plate type B for electric motors with 60 mm adaptor collar
7	---	motor mounting plate type C for electric motors
8	---	telescopic support for drill-Ø over 150 mm
9	---	set of wheels universal
10	---	quick-tensioning column for bracing
11	---	dowel set for fixing the drill column (refer to page 24)
12	VP-150	vacuum plate
13	VPU-206	vacuum pump, 230 V, 100 l/min
14	---	pipe drilling foot plate
15	---	1 set = 2 pcs. tension bands with ratchet, 4 m long; for pipe drilling foot plate
16	WSR	water collecting ring for drill-Ø 161 mm
17	---	seal disc for water collecting ring in various diametres

* in abrasive material

CORE DRILLING MACHINE P-2000

- drilling stroke 550 mm, with conversion kit 1200 mm
- electric or hydraulic drill drive
- integrated pivot function in steel dowel foot
- feed via constant-length chain
- easy, tool-free adjustment of carriage's slide guidance
- tool-free change of drill motor by motor mounting plate „dove tail“
- weight of drill column approx. 19,0 kg



P-2000 with hydraulic drill drive

P-2000 with electric drill motor BBM-33 L Extra



Max. drill-Ø for drill column with different drill motors

electric drill motor		max. drill-Ø with	
type	max. drill-Ø motor - mm -	mounting plate type C	mounting plate type C et distance plate
DK-32-EL C	350	315	350
C-BMS-300/3	300	295	300
BBM-33 L Extra	450	325	400
DK-52	500	315	400

BSP-3 and hydraulic drill motor	
type	max. drill-Ø - mm -
HM-51	151
HM-101	300
HM-161	400

P-2000 with hydraulic drill feed and electric drill motor DK-32-EL C



for drill-Ø up to 300/400* mm

* with mounted telescopic support

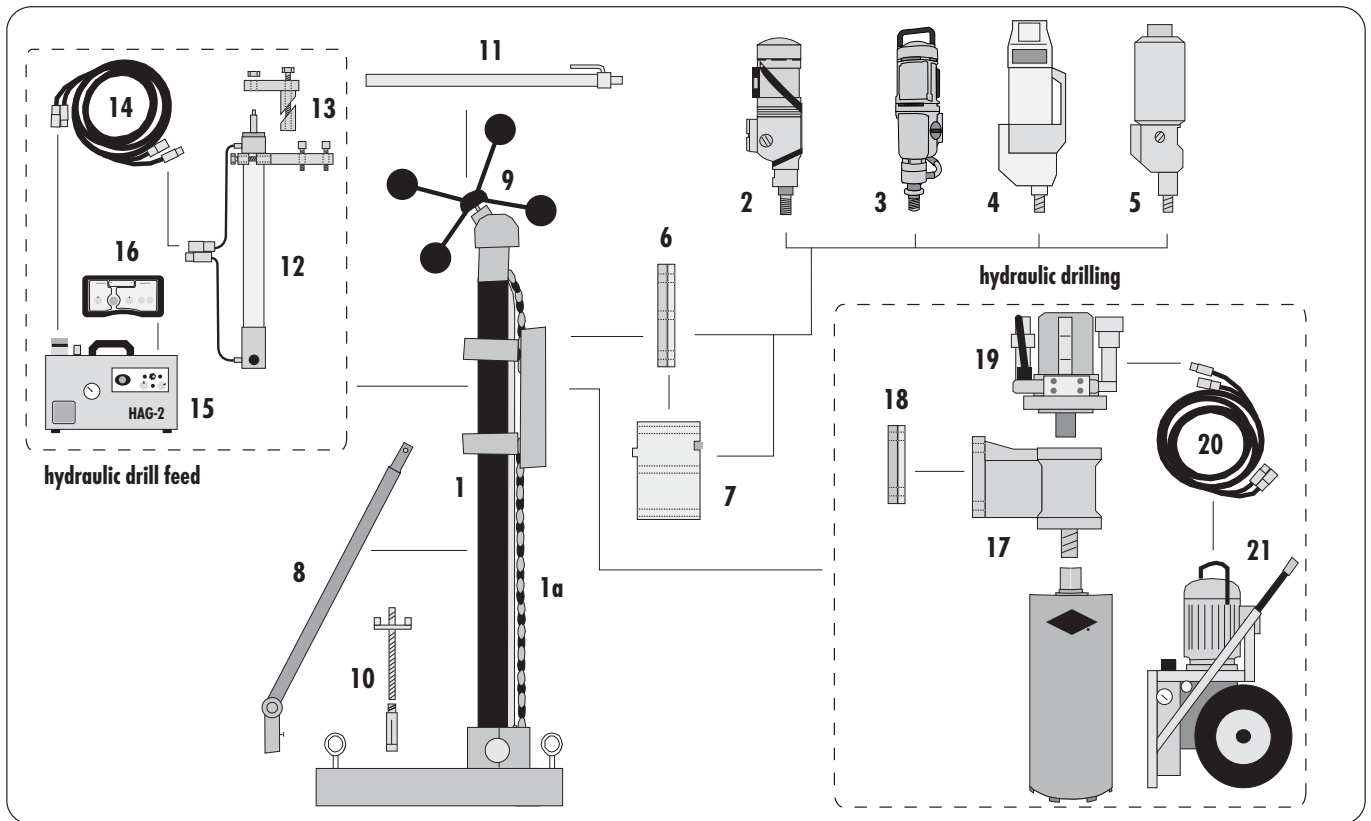

P-2000		
item		description
1	P-2000	double-column drill column with carriage, pivoting in steel dowel foot, feed via chain - mitre gear 1:3, drilling stroke 550 mm
1a	---	conversion kit for 1200 mm lifting (columns, chain, support)
2	BBM-33 L Extra	electric motor, 3,3 kW, 230 V, drill-Ø 45-450 mm
3	DK-32-EL C	electric motor, 3,0 kW, 230 V, drill-Ø 50-350 mm
4	C-BMS-300/3	electric motor, 3,0 kW, 230 V, drill-Ø 30-300 mm
5	DK-52	electric motor water-cooled, 5,2 kW, 400 V, drill-Ø 101-500 mm
6	---	motor mounting plate type C for electric motors
7	---	distance plate for drill-Ø extension by 120 mm (60 mm thick)
8	---	telescopic support for drill-Ø exceeding 300 mm
9	---	manual fine feed for P-2000
10	---	dowel set for fixing the drill column (refer to page 24)
11	---	quick-tensioning column for bracing
12	VZ-1	cylinder for hydraulic feed
13	---	assembly set for VZ-1
14	---	set of hoses 2-, 4 m long, feed HAG-2
15	HAG-2	power pack for hydraulic feed (refer to page 17)
16	---	universal control box with 10 m cable
17	BSP-3	drill spindle for hydraulic drill motors HM-51 to HM-360
18	---	mounting plate for BSP-3
19	HM	hydraulic drill motors (refer to page 22)
20	---	set of hoses 2-parts, 5 m long, with quick-couplings
21	HAG-12.10	hydraulic power pack; 15 kW/400 V; 30/44 l/min; 250 bar

CORE DRILLING MACHINES SERIES P-3000

- torsion-resistant stainless steel drill column 50 x 50 mm
- extra wide, high quality toothed rack
- long carriage for high stability and precision during drilling
- carriage guidance via heavy-duty, sealed special ball bearings and easily adjustable brass contact surfaces
- integrated swivel joint up to 45° with scale and locking function at 90°-position
- foot screws made of stainless steel with changeable threaded inserts made of brass
- integrated fine feed (1:3) and 4-armed hand wheel
- weight of P-3000 UNI approx. 14,5 kg, P-3000 PROFI approx. 17,0 kg



P-3000 PROFI with swivel and pivot joint in steel dowel foot and cylinder VZ-1 for hydraulic drill feed



P-3000 UNI with electric drill motor DK-32-EL C

Max. drill-Ø for drill column with different drill motors

drill column	drill motor		max. drill-Ø with	
	type	max. drill-Ø motor - mm -	mounting plate type C	mounting plate type C and distance plate
P-3000 UNI	C-BMS-200/3	200	200	-
	DK-32-EL C	350	340	350
	C-BMS-300/3	300	300	-
	BBM-33 L Extra	450	350	400
	DK-52	500	340	400
P-3000 PROFI	C-BMS-200/3	200	200	-
	DK-32-EL C	350	350	-
	C-BMS-300/3	300	300	-
	BBM-33 L Extra	450	380	400
	DK-52	500	370	400

for drill diameter up to 300/400* mm

* with mounted telescopic support

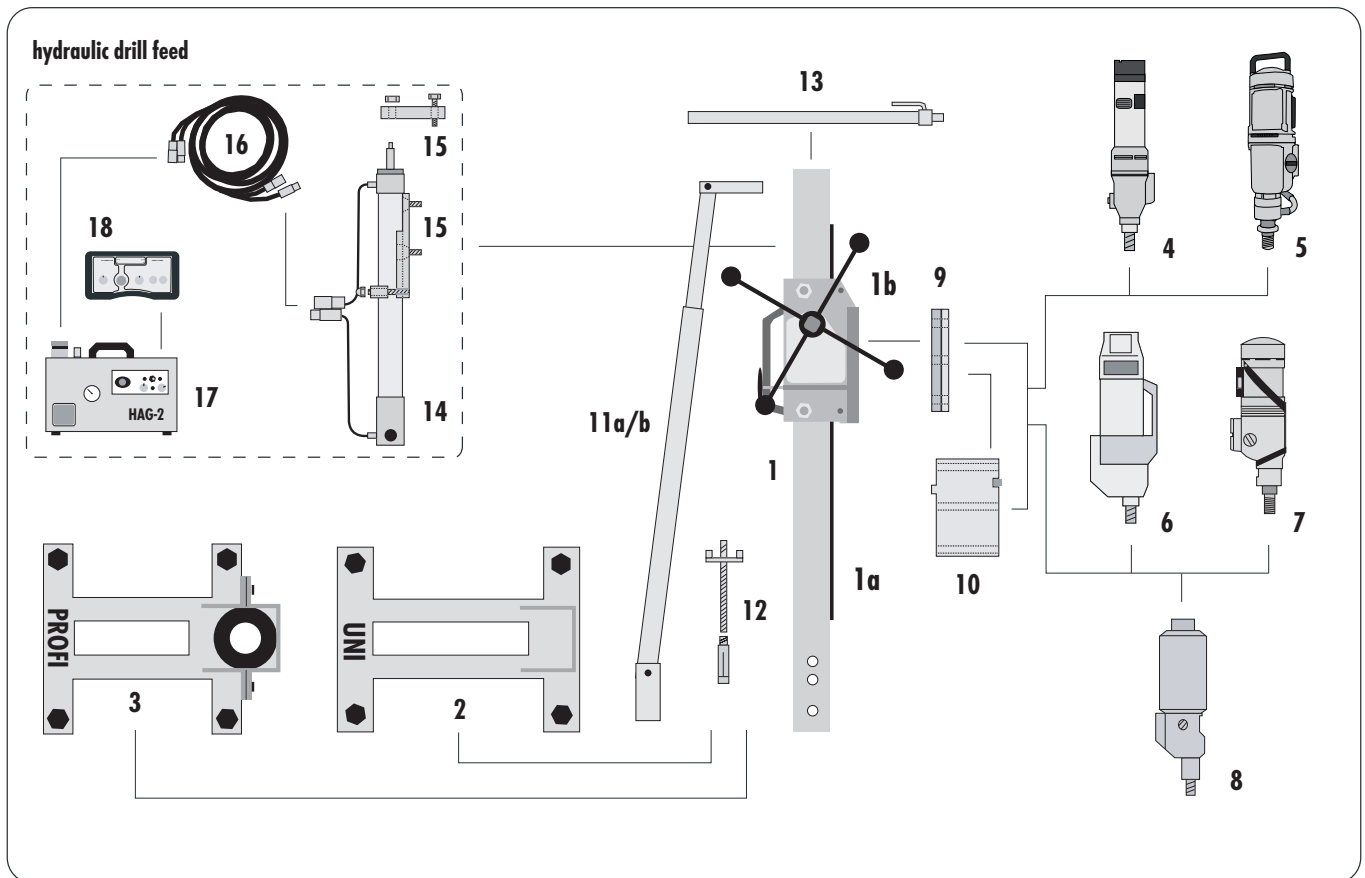

Serie P-3000

item		description
1	P-3000	drill column with carriage without steel dowel foot, integrated fine feed, drilling stroke 610 mm
1a	---	drill column without carriage and steel dowel foot, drilling stroke 1610 mm
1b	---	carriage with integrated fine feed
2	UNI-3000	steel dowel foot version UNI with pivot joint
3	PROFI-3000	steel dowel foot version PROFI with swivel and pivot joint
4	C-BMS-200/3	electric motor, 2,2 kW, 230 V, drill-Ø 35-200 mm
5	DK-32-EL C	electric motor, 3,0 kW, 230 V, drill-Ø 50-350 mm
6	C-BMS-300/3	electric motor, 3,0 kW, 230 V, drill-Ø 30-300 mm
7	BBM-33 L Extra	electric motor, 3,3 kW, 230 V, drill-Ø 45-450 mm
8	DK-52	electric motor water-cooled, 5,2 kW, 400 V, drill-Ø 101-500 mm
9	---	motor mounting plate type C for electric motors
10	---	distance plate for drill-Ø extension by 120 mm (60 mm thick)
11a	---	telescopic support for drill column with 610 mm lifting, drill-Ø exceeding 300 mm
11b	---	telescopic support for drill column with 1610 mm lifting, drill-Ø exceeding 300 mm
12	---	dowel set for fixing the drill column (refer to page 24)
13	---	quick-tensioning column for bracing
14	VZ-1	cylinder for hydraulic feed
15	---	assembly set for VZ-1
16	---	set of hoses 2-parts, 4 m long, feed HAG-2
17	HAG-2	power pack for hydraulic feed (refer to page 17)
18	---	universal control box 10 m cable

CORE DRILLING MACHINE P-6000

- stainless steel drill column 80 x 80 mm with 570 mm drilling stroke, with longer drill column up to 1570 mm
- integrated diagonal drilling joint in galvanised steel dowel foot
- carriage made of aluminium with integrated fine feed (1:4) and motor mounting plate type „dove tail“
- well sized 4-armed hand wheel, to be mounted on both sides
- carriage guidance by heavy-duty ball bearings and brass contact surfaces
- durable foot screws made of stainless steel in exchangeable threaded inserts made of brass

Max. drill-Ø for drill column with different drill motors

electric drill motor		max. drill-Ø with	
type	max. drill-Ø motor	mounting plate type C	distance mounting plate type K
BBM-33 L Extra	450 mm	420 mm	450 mm
DK-52	500 mm	410 mm	500 mm
		mounting plate type J	mounting plate type M
SR-75	900 mm	480 mm	800* mm
		mounting plate type N	mounting plate P
Beluga RX-SL	1000 mm	500 mm	800* mm

* with distance/mounting plate K



P-6000 with electric drill drive SR-75

Max. drill-Ø with hydraulic drill drive

BSP-3 and hydraulic drill motor

type	max. drill-Ø
HM-51	151 mm
HM-101	300 mm
HM-161	400 mm
HM-231	590/600* mm
HM-360	590/800* mm

* with distance/mounting plate K



P-6000 with high-frequency electric motor Beluga RX-SL and control box, additional set of wheels and support

for drill diameter up to 600/800* mm

*with mounted telescopic support

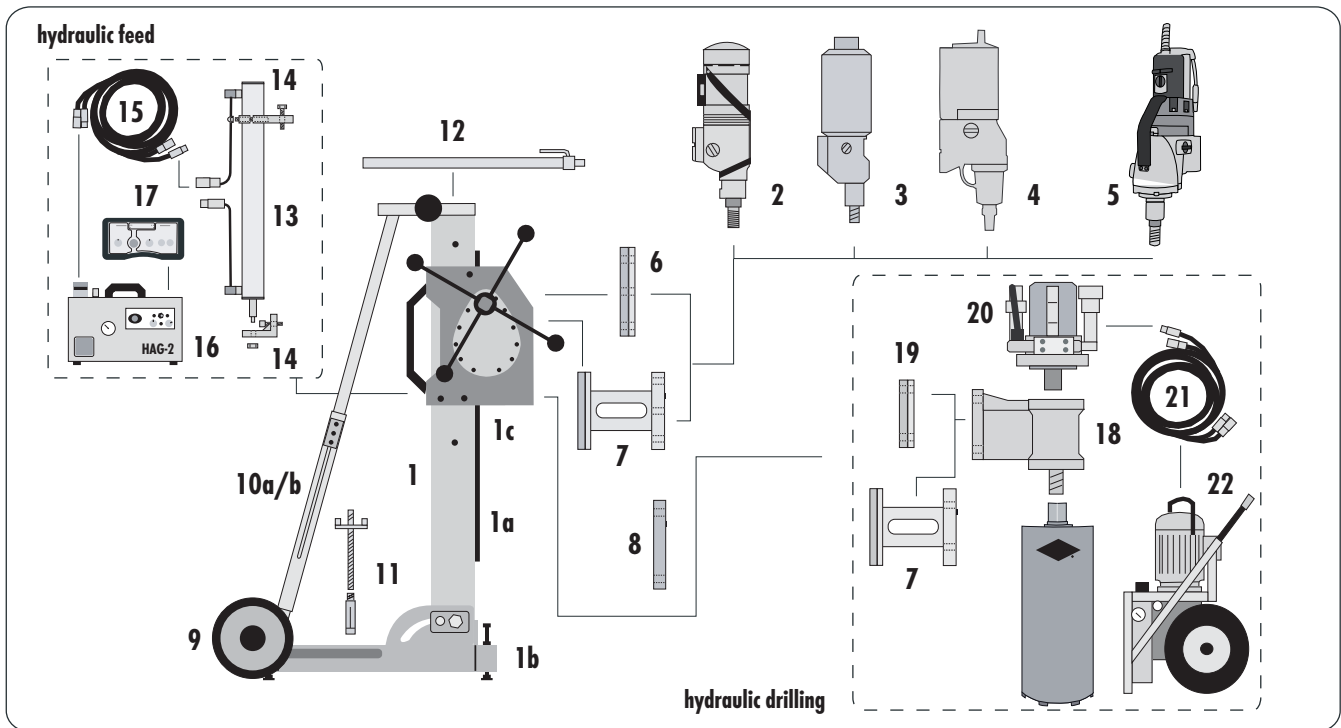

P-6000		
item		description
1	P-6000	drill column with carriage and steel dowel foot, integrated fine feed, drilling stroke 570 mm
1a	---	drill column without carriage and stand foot, drilling stroke 1570 mm
1b	DF-6000	steel dowel foot
1c	---	carriage with integrated fine feed and star handle
2	BBM-33 L Extra	electric motor, 3,3 kW, 230 V, drill-Ø 45-450 mm
3	DK-52	electric motor water-cooled, 5,2 kW, 101-500 V, drill-Ø 101-500 mm
4	SR-75	electric motor water-cooled, 6,0 kW, 400 V, drill-Ø 131-600 mm
5	Beluga RX-SL	high frequency-electric motor water-cooled, 8,0 kW, 400 V, drill-Ø 100-1000 mm, with control box
6	---	motor mounting plate for electric motors (required type refer to page 21)
7	---	motor mounting/distance plate type K (170 mm thick) for electric motors and BSP-3
8	---	adapter plates (required type referred to page 21)
9	---	wheel assembly set for P-6000
10 a	---	telescopic support with additional handles for drill column with 570 mm lifting, drill-Ø exceeding 600 mm
10 b	---	telescopic support with additional handles for drill column with 1570 mm lifting, drill-Ø exceeding 600 mm
11	---	dowel set for fixing the drill column (refer to page 24)
12	---	quick-tensioning column for bracing
13	VZ-2	cylinder for hydraulic feed
14	---	assembly set for VZ-2
15	---	set of hoses 2-parts, 4 m long, feed HAG-2
16	HAG-2	power pack for hydraulic feed (refer to page 17)
17	---	universal control box with 10 m cable
18	BSP-3	drill spindle for hydraulic drill motors HM-51 bis HM-360
19	---	mounting plate for BSP-3
20	HM	hydraulic drill motors (refer to page 22)
21	---	set of hoses 2-parts, 5 m long, with quick-couplings
22	HAG-12.10	hydraulic power pack; 15 kW/400 V; 30/44 l/min; 250 bar

DRILLING MACHINE FOR LARGE SIZED HOLES P-12500



- stable drilling machine for core drillings up to drill-Ø 1250 mm
- stainless steel drill columns 80 x 80 mm with exchangeable shafts
- lifting 550 mm or 1550 mm with long columns
- carriage made of aluminium with integrated fine feed (1:4) and motor mounting plate type „dove tail“
- combined carriage guidance by heavy-duty ball bearings and brass contact surfaces
- durable foot screws made of stainless steel in exchangeable threaded inserts made of brass
- 2 rolls integrated in the foot for drill bit-Ø from 950 mm and 2 freely adjustable pressure rolls
- drill bit connection 6-hole flange
- ring eye for transporting and relocating
- weight assembly set 90 kg
- weight columns/carriages 40 kg
- weight drill spindle 45 kg
- charge weight 175 kg



drill-Ø with BSP-4

oil consumption hydraulic motor	HAG-12.10 HAG-12.20	HAG-324
315 cm ³ /u	300 - 900 mm	250 - 600 mm
500 cm ³ /u	500 - 1250 mm	400 - 1250 mm

for drill diameter up to 1250 mm

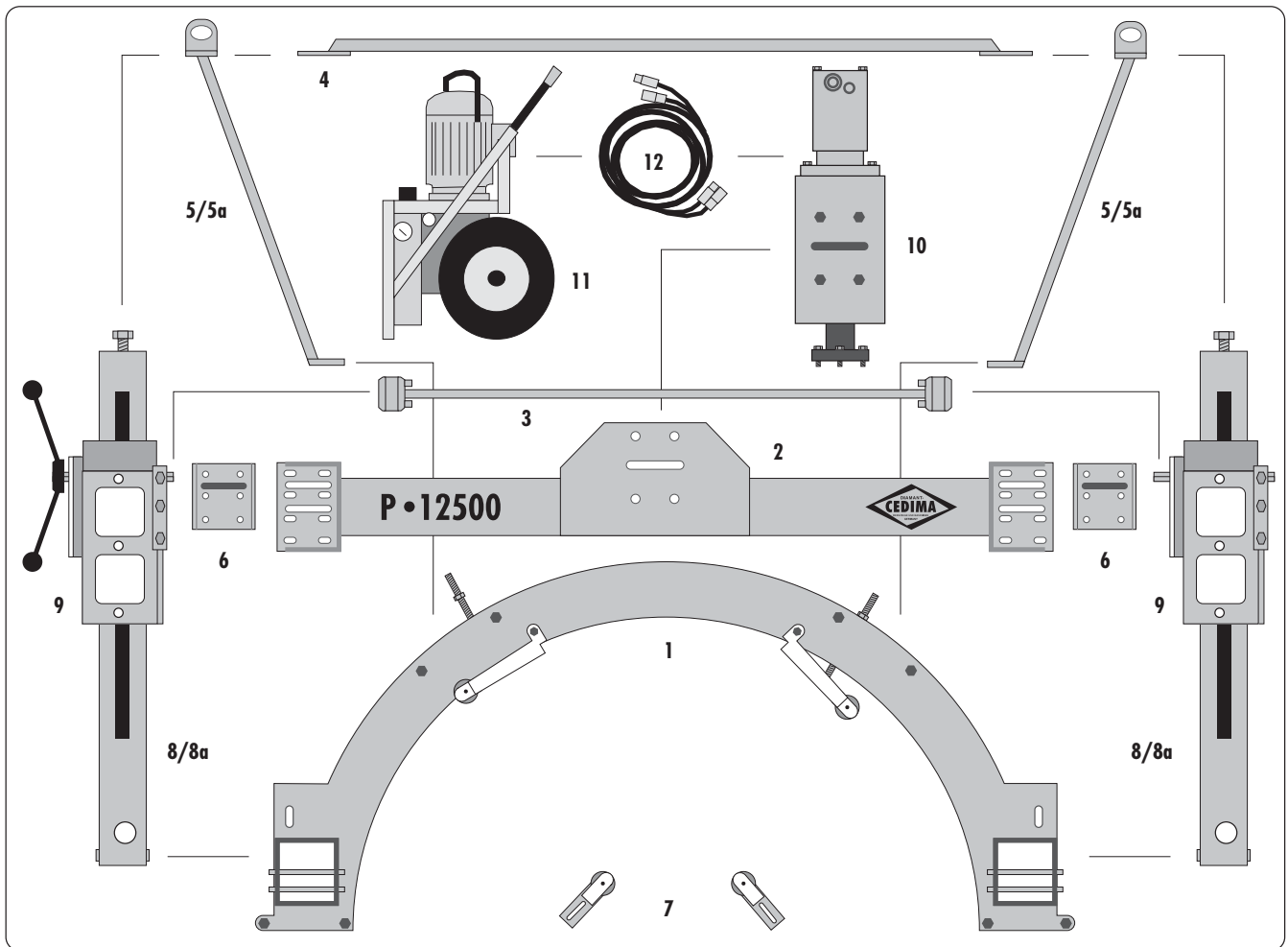

P-1250		
item		description
1		dowel foot with 2 displaceable rolls
2		drilling traverse
3		connecting shaft for feed
4		distance tube for stabilization of the drill columns
5	P-1250 assembly set	2 supports for drill columns with 550 mm lifting
6		2 mounting plates for drilling traverse with dove tail
7		2 freely positionable, displaceable pressure rolls
8	---	drill column without carriage, lifting 550 mm (2 pieces required)
8a	---	drill column without carriage, lifting 1550 mm (2 pieces required)
5a	---	support for drill columns with 1550 mm lifting (2 pieces required)
9	---	carriage with integrated fine feed and star handle (2 pieces required)
10	BSP-4	drill spindle with hydraulic motor, 500 cm ³ ; 6-hole-connection
10	BSP-4	drill spindle with hydraulic motor, 315 cm ³ ; 6-hole-connection
11	HAG-12.10	hydraulic power pack; 15 kW/400 V; 30/44 l/min; 250 bar
12	---	set of hoses 2-parts, 5 m long

DRY DRILLING SYSTEM CEBOR-2005

for drill diameter up to 151 mm

The CEDIMA dry drilling system CEBOR-2005 is designed for core drillings with a hand-held core drilling machine and dust aspiration. With the CEBOR-2005 you can create installation openings as well as openings for sockets and distribution boxes. A connected vacuum cleaner extracts the drill cuttings and the drill bits is cooled down at the same time.

- large drill depth (usable length of drill bit + 80 mm)
- comfortable handling due to system's short overall length
- available with connections for all current drill motors
- convincingly simple suction rotor for trouble-free operation

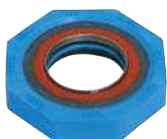

easy release ring



vacuum cleaner STARMIX



centring drill bit for CTB-11; usable length 300 mm



centring rod Ø 32 mm, usable length 250-300 mm

CEBOR-2005		
item		description
1	CEBOR-2005	suction rotor cpl. with connection M18x2,5 bushing
2	CEBOR-2005	suction rotor cpl. with connection 1¼" UNC bushing
3	CEBOR-2005	suction rotor cpl. with connection R½" pin
4	CEBOR-2005	suction rotor cpl. with connection 5/8" UNC bushing
5	CEBOR-2005	suction rotor cpl. with connection M16 bushing
6	Talpa 1800-162	electric motor, 1,8 kW, 230 V, max. drill-Ø 30-162* mm
7	C-BMH-152/3	electric motor, 2,0 kW, 230 V, drill-Ø 20-152/250*
8	---	centring drill bit for dry drill bit CTB-11, usable length 300 mm
9	---	replacement drill bit for items 9 and 10
10	---	centring rod Ø 32 mm for dry drill bit CTB-13.1, usable length 250 mm
11	---	easy-release ring for 1¼" UNC spindle
12	Starmix	vacuum cleaner 1,4 kW/230 V; container 50 l

* in abrasive material

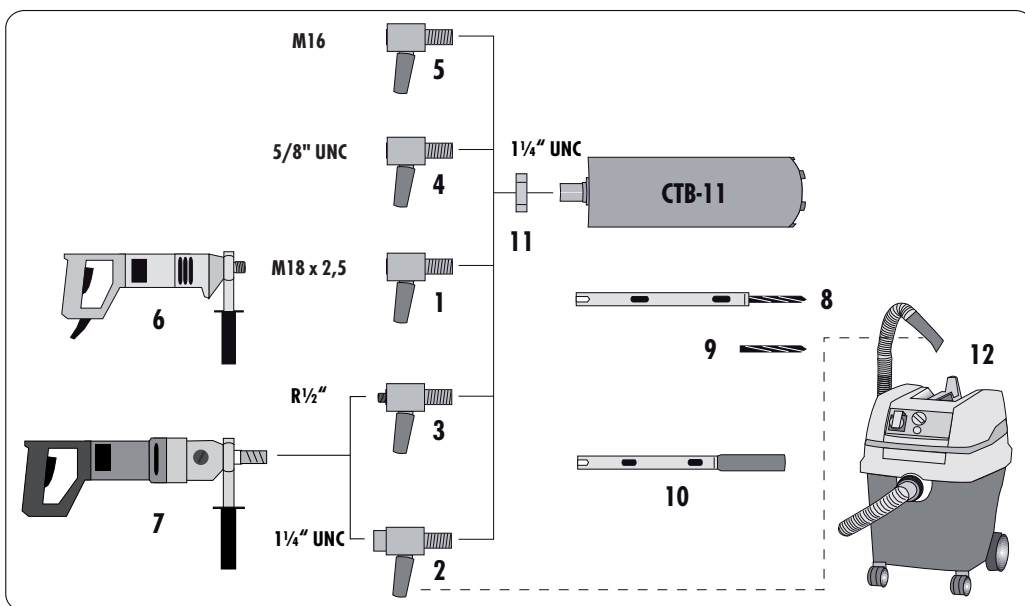

DRILLING SYSTEM EBL-33 CLICK

for drill diameter up to 120/450* mm

*only column-guided with planetary gear

The EBL-33 Click is a very versatile applicable drilling system for the professional user. The basic motor EBM-K 33 offers a highly stable full metal housing. By a snap closing system different attachments can be mounted for hand and column guided drilling operation. The equipment comes in a stable box made of non breakable plastic material.

Set 1

wet or dry drilling system hand-guided

- basic motor EBM-K 33
- attachment for wet drilling
- attachment for dry drilling
- hole starting aid and handle

Set 2

wet drilling system hand- or column-guided

- basic motor EBM-K 33
- attachment for wet drilling
- drill spindle for column operation*
- step-down gear 1:5,5 (planetary gear)
- handle

*attachment plate C required



Set 1



Set 2

drill diameter EBL - click

	hand-guided	supported by drill column	drill column with planetary gear
rear 1		130 - 250	400 - 450
rear 2	50 - 120	50 - 120	260 - 390
rear 3	25 - 40	25 - 40	130 - 250

technical data basic motor EBM-K 33

min rpm	450/1200/2500
min rpm with planetary gear	80/220/450
motor-output kW	2,3
voltage V/Hz	230/50
connecting thread	1 1/4" UNC + R 1/2"
l/w/h mm	300/110/425
weight kg	6,4

PIPE DRILLING MACHINE ROBO-351

for drill diameter up to 350 mm



- core drilling machine for creating connecting openings in concrete pipes for taking test cores from roadways
- robust double column, pivoting by 45° for inclined connecting openings
- max. drill-Ø 350 mm, drilling stroke 450 mm
- with petrol motor and compressed-water reservoir independent from supply lines
- operation independent from position
- various fixing possibilities
- weight of drill column approx. 19,0 kg

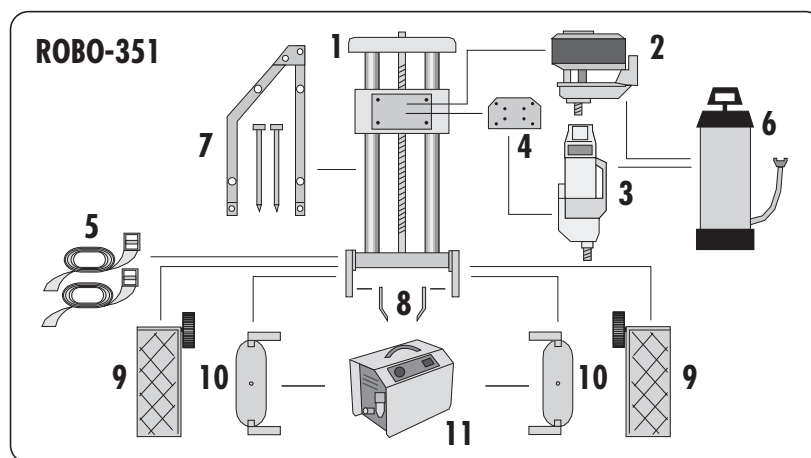

ROBO-351		
item		description
1	ROBO-351	drill column with carriage, drilling stroke 450 mm
2	FS-550	Stihl petrol motor with drill gear and flush head, 2,8 kW, 4 m exhaust hose, max. drill-Ø 350 mm
3	C-BMS-300/3	electric motor, 3,0 kW, 230 V, drill-Ø 30-300 mm
4	---	motor mounting plate type I for electric motors
5	---	1 set = 2 pcs. tension bands with ratchet, 4 m long
6	---	compressed-water reservoir 10 l with hose of 5 m
7	BR-351	ground frame with 2 earth nails
8	GV-351	frame extension for pipe-Ø from 270 - 380 mm
9	SP-351	1 set = 2 pcs. stand plates with transport wheels
10	VP-351	1 set = 2 pcs. vacuum plates
11	VPU-206	vacuum pump, 230 V, 100 l/min

Accessories for ROBO-351



ground frame with earth nails



frame extension



motor mounting plate type I



vacuum plates

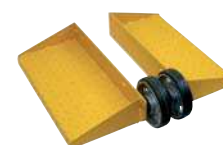

stand plates

HYDRAULIC DRILL FEED

The hydraulic drill feed optimises the drilling operation by means of an automatic pressure control for drill motors with 230 V/16 A to an output of approx. 3,5 kW, connected to the socket of the HAG-2. After the operator has adjusted the maximum current of his drill motor at the HAG-2, the feed system always works with the best possible output curve. This makes it easier for the operator and accelerates the drilling operation. The hydraulic drill feed is operated via the control panel of the HAG-2 or a hand-held universal control box (accessories). Presently, the automatic drill feed can be operated with the following CEDIMA drill columns: P-2000, P-3000 series, P-6000, but only with an additionally mounted support at the drill column. Furthermore, the HAG-2 can be used as a feed pack for CEDIMA automatic wire saws with high-frequency electric drive or as amendment for hydraulic power packs with only one oil circuit.

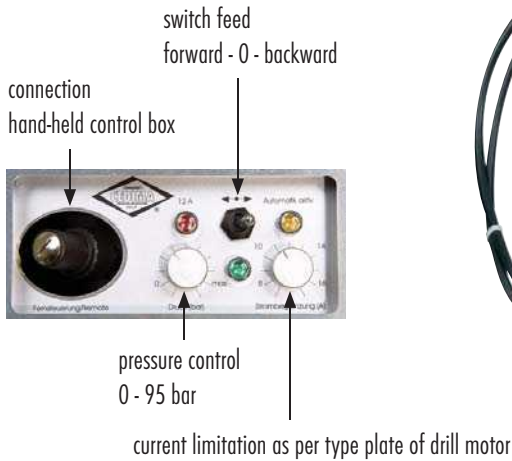

Functions of HAG-2

- On / Off / emergency stop
- switch feed : forward - 0 - backward
- pressure control 0 - 95 bar
- pressure gauge
- hydraulic quick-couplings (BG 1)
- Schuko socket for drill motor
- LED-display for motor current 12 A
- automatic pressure control after adjustment of max. current (as per motor's type plate)
- connection for hand-held control

Functions of hand-held control box (accessories)

- emergency stop
- switch feed : forward - 0 - backward
- pressure control 0 - 95 bar

universal control box for remote control of HAG-2

technical data HAG-2	
system pressure	0 - 95 bar
volume flow	1,25 l/min
oil quantity	1,2 l
voltage	230 V
amperage (without further consumer loads)	1,2 - 2,5 A
max. output of hydraulic power pack	250 W
output control for electric motors up to max.	230 V/16 A/3,5 kW
cooling	oil-air integrated
control/protection of power pack	thermal
feed cylinders VZ-1 and VZ-2	400 mm lifting

DRILL TRAILER BW-300

for drill diameter up to 400 mm

The BW-300 is ideal for taking test cores from asphalt or concrete surfaces. On airfields the drill trailer is used for drilling holes for flush lights on runways. With the BW-300 you can work independently from any supply lines.

- drill feed as well as raising and lowering of drill platform by means of hydraulic
- hydraulic control panel to be fixed left or right
- 2-speed-gearbox
- Niro-water tank with large filling opening
- mechanical water pump
- warning beacon
- petrol motor with electric starter
- overrun brake with electric starter
- large storage box
- ball-type tow hook
- TÜV/MOT-approved for road use

Special accessories

- centering device
- height-adjustable ring-eye coupling



technical data BW-300		
max. drill-Ø	mm	400
max. lifting	mm	600
max. usable length of drill bit	mm	550
drill bit connection	-	1 ¼" UNC pin
motor output	kW	9,6 / 7,6
motor type	-	Honda GXV-390 (petrol)
contents water tank	l	300
water pump	-	mechanical
lowering and feed	-	hydraulic
drive of drill bit	-	mechanical (2-speed-gear)
dimensions l/w/h	mm	3300/1660/1800
weight (unladen/max. permissible)	kg	700/1200
sound pressure level	dB(A)	92,7
sound power level	dB(A)	107,3



water filling opening

accessories drill trailer BW-300	
description	
centering device	(assembly at works for new machine)
height-adjustable ring-eye coupling	(assembly at works for new machine)

DRILL TRAILER BW-400 H

for drill diameter up to 600 mm

The fully-hydraulic BW-400 is suitable for taking cores from asphalt or concrete surfaces. On airfields the drill trailer is used for drilling shouldered holes for flush lights on runways. With the BW-400 H you can work independently from any supply lines.



- 2-cylinder Hatz diesel motor with sound insulation hood
- drill feed as well as raising and lowering of drill platform by hydraulic
- infinitely adjustable speed
- Niro-water tank with large filling opening
- switchable electric water pump
- overrun brake with automatic reverse motion
- warning beacon and large storage box
- ball-type tow hook
- TÜV/MOT-approved for road use

technical data BW-400 H		
max. drill-Ø	mm	600
max. lifting	mm	600
max. usable length of drill bit	mm	550
drill bit connection	-	1 1/4" UNC-pin
motor output	kW	15,4
motor type	-	Hatz 2 G 40 (diesel)
contents water tank	l	300
water pump	-	electric
lowering and feed	-	hydraulic
drive of drill bit	-	hydraulic
dimensions l/w/h	mm	3300/1700/1830
weight (unladen/max. permissible)	kg	920/1500
sound pressure level	dB(A)	91
sound power level	dB(A)	109

selection of motor		
drill-Ø -mm-	hydraulic motor	distance plate required
80 - 300	H-100 (mounted)	no
300 - 400	H-230 (accessories)	no
400 - 600	H-230 (accessories)	yes

accessories drill trailer BW-400 H
description
distance plate for drill-Ø > 400 - 600 mm
hydraulic motor H-230, 120 - 190 rpm
height-adjustable ring-eye coupling (assembly at works for new machine)

ELECTRIC DRILL MOTOR SR-75 JUMBO

- extremely powerful drill motor with 7,5 kW output
- rpm basically constant for the total range of performance
- very high torque of 628 Nm in 1. gear
- electronic and thermique overload protection
- long-lasting multi disc clutch protecting against mechanical overload
- optimal cooling and safety by cooling duct completely seperated from the electric
- low-maintenance, as without carbon brushes and without turning coil
- robust, thermically stable aluminium housing



SR-75 Jumbo rpm ranges			
	1. gear	2. gear	3. gear
motor step 1 ⁽¹⁾	60	115	145
motor step 2 ⁽²⁾	80	160	250
motor step 3	100	195	300

⁽¹⁾ reduced output of motor step ⁽²⁾ nominal rpm

3 gears x 3 motor stages = 9 possible rpm

Besides the 3 steps of the mechanical transmission the motors provide 3 electronically controlled motor stages. Steps 2 and 3 are designed as power stages. Step 1 is reduced in output and especially suited for spot drillings with large drill bits.

Operating the drill motor:

- push the start button: motor will run in step 2 (nominal rpm)
- then shortly push the start button (< 1 s): motor will change to step 3 (high rpm)
- or push the start button for a longer time (> 1 s): motor will change in step 1 (slow rpm)

HIGH-FREQUENCY ELECTRIC DRILL MOTOR BELUGA RX-SL

- extremely powerful high frequency drill motor with 8 kW output
- very high torque of 1500/750* Nm in the 1. gear
- 4-step mechanical transmission
- each gear electronically adjustable between 0 and maximum rpm
- basically constant output for the total range of rpm (synchronous motor)
- technical data refer to page 21

*400/230 V operation



- power box in modern aluminium housing
- operation with 230 or 400 V
- cooling alternatively by ventilator or with water
- continuous adjustment of output by control dial
- emergency cut-out

technical data control box

voltage V/Hz	400 oder 230/50
type of protection	IP67
cooling	air / water
weight kg	16,5

mechanical gear speeds



ELECTRIC DRILL MOTORS



drill motor	Talpa 1800-162 only dry drilling	Talpa 1800-102-41 EL	C-BMH-152/3	DK-17 EL	C-BMS-200/3
drill-Ø from-to mm	30 - 162*	60 - 102 (162*)	20 - 152 (250*)	20 - 160 (200*)	35 - 200
rpm	920	580	530/1280/1780	540/1200/2520	385/920/1280
motor output kW	1,8	1,8	2,0	2,0	2,2
voltage V/Hz	230/50	230/50	230/50	230/50	230/50
connecting thread	M18x2,5	R½"+1¼" UNC	R½"+1¼" UNC	R½"+1¼" UNC	R½"+1¼" UNC
l/w/h mm	200/120/450	200/120/470	156/120/540	300/100/425	120/110/488
weight kg	4,6	4,6	6,8	6,3	7,3



* in abrasive material

drill motor	DK-32-EL C	C-BMS-300/3	BBM-33 L Extra	DK-52 water-cooled	SR-75 water-cooled	Beluga RX-SL high-frequency, water-cooled
drill-Ø from-to mm	50 - 350	30 - 300	45 - 450	101 - 500	150 - 900	100 - 1000
rpm	230/480/720	220/500/935	180/430/750	120/240/360	60/300	0 - 100/180/250/480
motor output kW	3,0	3,0	3,3	5,2	7,5	8,0
voltage V/Hz	230/50	230/50	230/50	400/50	400/50	400/50 (control box)
connecting thread	1¼" UNC	1¼" UNC	1¼" UNC	1¼" UNC	1¼" UNC	1¼" UNC
l/w/h mm	140/110/490	160/130/482	168/142/509	160/340/570	170/200/620	230/160/580
weight kg	11,9	12,2	13,2	22,5	19,5	4,8

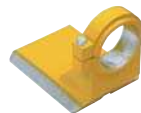

motor mounting plate type B



motor mounting plate type C



motor mounting/distance plate type K (170 mm thick)

motor mounting plates and adaptor plates with selection chart		
plate	application with drill column	application with drill motor
mounting plate B	all CEDIMA drill columns	Talpa 1800-162, Talpa 1800-102-41, C-BMH-152/3, DK-17, motors with adaptor collar Ø 60 mm
mounting plate C	except ROBO-351	C-BMS-200/3, C-BMS-300/3, DK-32-EL C, BBM-33 L Extra, DK-52
mounting plates J / N	P-6000	Typ J for SR-75, Typ N for Beluga RX-SL
adaptor plates M / P	P-6000	Typ M for SR-75, Typ P for Beluga RX-SL (only in connection with type K)
mounting/distance plate K	P-6000	DK-52, hydraulic drill spindle BSP-3

HYDRAULIC DRILLING

For heavy drilling operations hydraulic drill drives are utilised. The hydraulic drill motors are operated in combination with the drill spindle BSP-3.



drill spindle BSP-3 and hydraulic motor with control valve and pressure relief valve

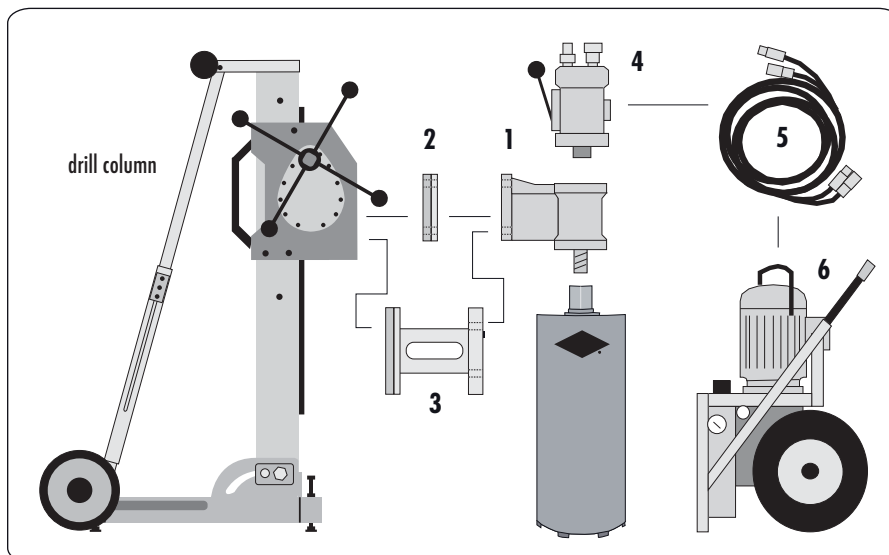

motor mounting/distance plate type K (170 mm thick)

components for hydraulic drilling P-2000, P-4000, P-6000		
item	type	description
1	BSP-3	drill spindle for hydraulic drill motors HM-51 to HM-360
2	---	mounting plate BSP-3
3	type K	combined motor mounting/distance plate for BSP-3 (drill-Ø extension by 300 mm)
4	HM	hydraulic drill motor (refer to chart below)
5	---	set of hoses 2-parts, 5 m long, with quick-couplings
6	HAG-12.10	hydraulic power pack; 15 kW/400 V; 30/44 l/min; 250 bar

hydraulic drill motors with control valve and pressure relief valve for BSP-3					
drill motor	HM-51	HM-101	HM-161	HM-231	HM-360
drill-Ø from-to mm	51 - 151	121 - 300	201 - 400	300 - 600	400 - 800
max. rpm	900	610	370	260	190
max. oil flow l/min	45	60	60	60	60
oil consumption cm ³ /u	50	98	163	228	360
dimensions l/w/h mm	185/255/260	185/255/260	185/255/260	185/255/260	220/185/280
weight kg	10,1	10,5	11,0	11,7	19,5

HYDRAULIC POWER PACKS



type	HAG-311.2 B	HAG-12.10	HAG-12.20	HAG-324
output electric motor S1/S6	-	15/20 kW	15/20 kW	18,5/24 kW
voltage/amperage	-	400 V/50 Hz/32 A	400 V/50 Hz/32 A	400 V/50 Hz/35 A
petrol motor	Honda 9,6 / 8,2 kW	-	-	-
hydraulic pump	wheel gear	double wheel gear	triple wheel gear	triple wheel gear
oil flow capacity operating circuit	30 l/min	30/44 l/min	30/44 l/min	40/54 l/min
oil flow control circuit	-	14 l/min**	6 l/min	6 l/min
working pressure	140 bar	250 bar	250 bar	250 bar
solenoid valve	no	yes	yes	ja
oil quantity in tank	7,5 l	11 l	11 l	11 l
weight electric motor	-	62 kg	62 kg	71 kg
total weight	86 kg	130 kg	130 kg	137 kg
dimensions l/w/h	820/480/570 mm	640/560/970 mm	640/560/970 mm	640/560/1000 mm

* for hydraulic application only ** in operating circuit 30 l/min available

GUIDE VALUES FOR ROTATIONAL SPEED OF DRILL BITS

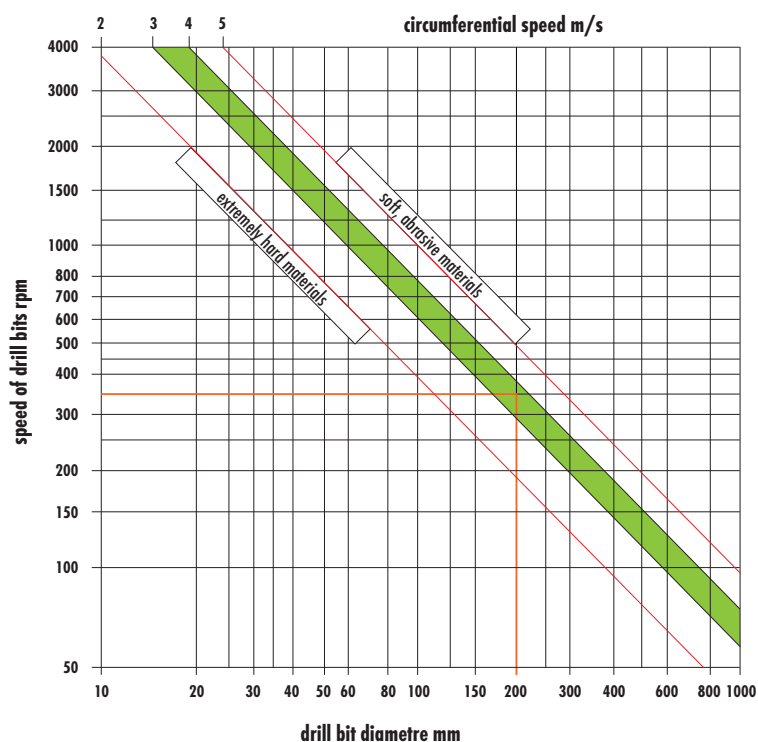

ACCESSORIES FOR DIAMOND DRILLING TECHNOLOGY

Fixing of drill columns



fixing tool for dowel set DS-200



drill-Ø	- 200 mm	- 350 mm	- 800 mm
suitable dowel set	dowel set DS-200 (drill-Ø 16 mm)	dowel set DS-350 (drill-Ø 16 mm)	dowel set DS-800 (drill-Ø 20 mm)



vacuum plate VP-150 for P-1500



vacuum pump VPU-206,
230 V, 100 l/min



pipe drilling foot plate for
H-201 series, P-1500



quick-tensioning column
for bracing

Drill bit extensions



drill bit extension made of steel with
6-hole flange connection,
lengths: 500 und 1000 mm



drill bit extension made of steel
1/4" UNC, Ø 47 mm,
lengths: 100, 200, 300 and 500 mm



drill bit extension made of steel
R1/2", Ø 30 mm, length: 300 mm



drill bit extension made of aluminium
1/4" UNC for hand-held machines,
Ø 47 mm, lengths: 300 and 500 mm

Adapter pieces



adaption of R1/2"-pin to 1/4" UNC-pin



adaption of R1/2"-bushing to 1/4" UNC-bushing



adaption of 1/4" UNC-bushing to 6-hole flange connection

Further accessories



compressed-water reservoir 10 l for
water supply, 5 m hose



telescopic drilling support for
DK-17, NL 300 - 350 mm



easy-release ring drill motor- drill bit



distance plate 60 mm for drill-Ø
extension by 120 mm



water collecting ring with holder
up to drill-Ø 161 mm

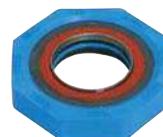

easy-release ring drill motor- drill bit



copper rings for easier release
of drill bit from drill motor

DIAMOND DRILL BITS

drill bits for reinforced concrete, connection 1 1/4" UNC bushing, usable length 450 mm



type	application	drill-Ø mm
CIB-16	for medium-hard aggregates at low to medium shares of reinforcement	25 - 400
CIB-52.1	for hard to very hard aggregates at high shares of reinforcement	25 - 600
CIB-60.1	for hard to very hard aggregates at high shares of reinforcement	25 - 600

larger drill-Ø on request

ring drill bit for reinforced concrete, connection R 1/2" pin, usable length 300 mm

type	application	drill-Ø mm
CDK-18	for medium-hard aggregates at low to medium shares of reinforcement	12 - 41



sewer pipe for concrete pipes, connection 1 1/4" UNC bushing, usable length 350 mm*



type	application	drill-Ø mm
CRB-16	for making connecting openings in concrete pipes	166 - 330

* in -Ø 166, 201 and 257 mm also available with 3-hole-Stihl connection, usable length 300 mm

drill bit for abrasive material, connection 1 1/4" UNC bushing or without connection, usable length 450 mm

type	application	drill-Ø mm
CAB-02	for asphalt, lime sand-stone, masonry and other abrasive materials	107 - 201



DRILL BITS FOR DRY DRILLING

drill bit for dry drilling type CTB-11, connection 1 1/4" UNC bushing, usable length 300 mm

type	application	drill-Ø mm
CTB-11	for masonry, lime sand-stone, Poroton, bricks with dry drilling system CEBOR-2005 and hand-held drill motor DK-17 EL	41 - 225



Recess cutters type CDS-12 and CDS-13, connection M16 SW24, usable length 62 mm



type	application	drill-Ø mm
CDS-12 Laser	for masonry, Poroton and lime sand-stone	68 und 82
CDS-13 Laser	for high-compressed lime sand-stone	68 und 82

adaptors for recess cutters, connection M16 pin



receptacle for drill motors with drill chuck 13 mm



receptacle for drill motors with connection
M18x2,5 pin (e.g. Talpa 1800-162)



SDS-Plus receptacle



centre drill bit 8 mm for adaptor



centre drill bit 6,5 mm for adaptor

accessories for re-tipping of drill bits



diamond segments for re-tipping
of drill bits



soldering magnet

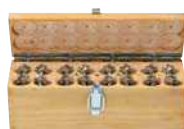

set of soldering magnets (16 pcs.)



flux and silver solder



assortment box

SCREW-TYPE DRILL BITS TYPE CSK

type A drill-Ø outer x inner -mm-	type B drill-Ø outer x inner -mm-
20 x 9	---
26 x 15	---
30 x 19	---
36 x 25	---
40 x 29	---
46 x 35	46 x 32
56 x 45	56 x 42
66 x 55	66 x 52
76 x 65	76 x 62
86 x 75	86 x 72
101 x 87	101 x 86
116 x 102	116 x 101
131 x 117	131 x 116
146 x 132	146 x 132
163 x 149	163 x 148
171 x 151	171 x 151
181 x 161	181 x 161
206 x 186	206 x 186
222 x 202	222 x 202
248 x 228	248 x 228
276 x 256	276 x 256

For drillings of excess length screw-type drill bits can be used. The drill bit can be extended as required by adding extension tubes. The drill bit will be manufactured according to your drilling task. Please observe our ordering information!

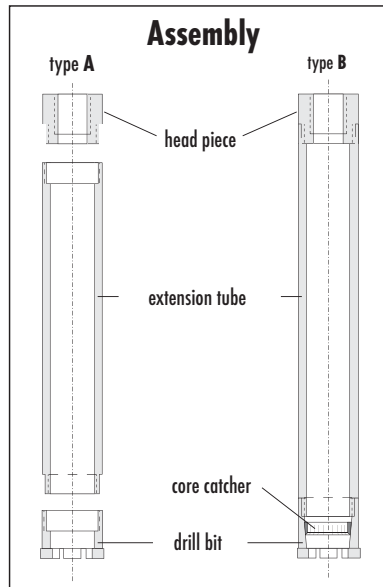

For types A and B each 2 versions are possible: Standard and Mining

Accessories:

- pliers for separating the connecting tubes
- reamer for bore armouring
- core catchers for type B
- copper grease



drill bit type A	drill bit with standard segments
drill bit type B	drill bit with wide segments to be used with core catcher
Standard version	standard drill bit with segments to be used in solid materials
Mining version	drill bit with segments and TC bore protection, preferably for drilling operations in loose rock or masonry and for horizontal drillings
head piece	connection to drill motor or drill spindle with 1 1/4" UNC-bushing
extension tubes	in lengths of 500 and 1000 mm for any drill-Ø
reamers	diamond or tungsten carbide tipped; prevents sagging of drill bit when drilling long horizontal holes
core catcher	keeps the core inside the bit when retracting the drill bit

Segment specifications

type No.	
-10	very abrasive masonry, abrasive sand-stone
-20	brick masonry, fine-grained sand stone, abrasive concrete without reinforcement
-30	concrete with medium-hard aggregates and low shares of reinforcement
-40	concrete with medium-hard aggregates and normal shares of reinforcement, hard lime sand-stone, slate

type No.	
-50	concrete with medium-hard to hard aggregates and high shares of reinforcement, basalt, marble
-60	gneiss, granite, porphy
-70	very hard, non-abrasive artificial and natural stones at low machine output

Ordering information

Please order as follows: Ø CSK - type of drill bit - version - Segment-type

Example: You intend to drill a blind, horizontal hole of 5 m depth and Ø 101 mm in loose brickwork using a screw-type drill bit.

Order:

- 1 piece 101 mm CSK - B - mining - 20
- 1 piece head piece Ø 101 mm
- 5 pieces extension tube 1000 mm Ø 101 mm
- 1 piece reamer Ø 101 mm
- 1 piece core catcher Ø 101 mm



- **DIAMOND SAW BLADES**

for wet and dry cutting in concrete, reinforced concrete, asphalt, natural stone;
saw blade diameter from 110 to 2200 mm

- **DIAMOND DRILL BITS**

for wet and dry drilling in concrete, reinforced concrete, asphalt, natural stone;
drill bit diameter from 12 to 1200 mm

- **DIAMOND TOOLS**

grinding discs for hand-held and floor grinding machines, diamond wires,
chamfering discs, diamond chains, diamond segments

- **JOINT CUTTERS**

with petrol, diesel or electric motor, with and without automatic feed;
cutting depths to 900 mm

- **CORE DRILLING MACHINES**

hand-held drilling machines and drill columns with electric or hydraulic
drill motor; drill diameter from 12 to 800 mm

- **WALL SAWS & WIRE SAWS**

electric, hydraulic and electro-hydraulic wall saws up to 730 mm cutting depth;
automatic wire saws, circular saw

- **TABLE SAWS**

for cutting tiles, glazed tiles, general building materials or
large-sized stones; cutting depths up to 425 mm

- **SPECIAL MACHINES**

reinforced concrete breaker, floor grinding machines, surface milling machine,
chain saws, hand-held saw

CEDIMA[®] Diamantwerkzeug- und Maschinenbaugesellschaft mbH

Lärchenweg 3 • 29227 Celle/Deutschland

Tel. +49 (0)51 41/8 854-0 • Fax +49 (0)51 41/6 427

Internet: www.cedima.com • E-Mail: info@cedima.com

