

LISSMAC

CONSTRUCTION TECHNOLOGY

OPERATING MANUAL CELLULAR CONCRETE BAND SAWS

MBS 510
MBS 650
MBS 760



LISSMAC Maschinenbau GmbH
Lanzstrasse 4
D-88410 Bad Wurzach
Telephone +49 (0) 7564 / 307- 0
Fax +49 (0) 7564 / 307 - 500
lissmac@lissmac.com
www.lissmac.com





Imprint

The operating manual is valid for:
LISSMAC Cellular concrete band saws

- MBS 510
- MBS 650
- MBS 760

Company headquarters:



LISSMAC Maschinenbau GmbH
Lanzstraße 4
D - 88410 Bad Wurzach
Phone: +49 (0) 7564 / 307 – 0
Fax: +49 (0) 7564 / 307 – 500
lissmac@lissmac.com
www.lissmac.com

Translation of the original operating manual
Status: 09-2015

The dissemination or duplication of this operating manual in any form, or the reuse of contents is forbidden unless permitted in writing.
Non-compliance is subject to compensation for damages. All rights reserved for the purpose of patent, utility model, or design patent registration.

BASIC SAFETY INSTRUCTIONS

Warning notices and symbols in this operating manual

 Danger!	Indicates that failure to comply could lead to severe injury or even death.
 Caution!	Indicates that failure to comply could sometimes lead to injuries.
 Note	Indicates that failure to comply leads to damage to the machine or other property.

The defined sequence of the handling steps makes proper and safe handling of the machine easier.

- Handling instructions for the operator

The following warning and safety symbols were attached on the machine:

	Observe the operating manual
	Wear safety glasses and hearing protection
	Wear hand protection
	Warning due to rotating saw belt
	Attachment point for crane transport
	No attachment point for crane transport
	Noise power level (noise level) of the machine
	Running direction of saw belt
	Align saw band
	Tightening and releasing the saw belt

OPERATING MANUAL

Preface

This operating manual should make it easier to get to know the machine and make use of its intended applications.

The operating manual contains important information on how to operate the machine safely, properly and economically. Your close attention helps avoid risk, repair costs and downtime, and increase the reliability and lifetime of the machine.

The operating manual is to be supplemented by directives for accident prevention and environmental protection, according to applicable national requirements.

The operating manual is to be kept permanently available at the machine location.

The operating manual must be read and used by each person assigned to work with the machine, e.g.:

- Operating, including tooling, troubleshooting during operating, correction of production rejects, service, disposal of operating and auxiliary materials
- Maintenance (service, inspection, repair) and/or
- Transport

Along with the operating manual and the valid legal regulations for accident prevention in the country of use and the place of use, also recognised regulations for safety and proper work are to be observed.

Required tool

In order for the cellular concrete band saw to be operated, a tool - in the form of a saw belt - is required. These tools can be purchased from the manufacturer.

Changes and reservations

We attempt for this operating manual to be correct and up-to-date. To maintain our technological lead, it can be necessary to change the product without advance notice and to perform their operation. We accept no liability for malfunctions, breakdowns and damage caused by this.

Notes:

1. Description of performance	8
1.1. Basics of intended use.....	9
1.2. Organisational measures.....	9
1.3. Personnel choice and personnel qualification; basic responsibilities.....	10
1.4. Safety instructions and residual risks for the operation phases of the machine.....	11
1.4.1. Transport, assembly and installation.....	11
1.4.2. Moving the cellular concrete band saw.....	11
1.4.3. Commissioning.....	11
1.4.4. Operation.....	12
1.4.5. Blockage of the cellular concrete band saw.....	12
1.4.6. Special work while using the machine.....	13
1.5. Safety instructions for special types of dangers.....	13
1.5.1. Danger for the operator by the machine.....	13
1.5.2. Electric power.....	14
1.5.3. Dust.....	14
1.5.4. Noise.....	14
1.6. Transport.....	14
1.7. Packaging and Storage.....	15
1.8. Environmental protection.....	15
1.9. Disposal.....	15
2. Description of the device	16
2.1. Name of machine parts.....	16
2.2. Safety guards.....	16
2.3. Technical data.....	17
2.4. Noise power level.....	17
3. Commissioning	18
3.1. Connections and operating materials.....	18
3.2. Setting up the cellular concrete band saw.....	18
3.3. Running direction of the saw belt (only 400 V).....	19
3.3.1. Changing running direction of the saw belt.....	19
3.4. Check distance between saw belt and guide rollers.....	20
3.5. Preparing to Start and Setting Operating Range.....	21
4. Transport	23
4.1. Transport position.....	23
4.2. Move with the crane.....	24
4.3. Moving the cellular concrete band saws.....	24
5. Operation	26
5.1. Safety.....	26
5.2. Cutting with the cellular concrete band saw.....	26
5.3. Replacing the saw belt.....	27
5.4. Workpiece blockage.....	28
5.5. Selection of the tools.....	28
6. Cleaning	28
7. Dismantling	29
8. Maintenance	29
8.1. Service.....	29
8.2. Lubrication points.....	30
8.3. Troubleshooting table.....	31
8.4. Torque of screw connections.....	32
8.5. Maintenance plan.....	33
9. Warranty	34
10. Spare parts list MBS 510 & 650	35
11. Spare parts list MBS 760	40

1. DESCRIPTION OF PERFORMANCE

Cellular concrete band saws from LISSMAC are designed especially for processing porous concrete and have proven themselves on all types of construction sites worldwide. The different models in the MBS product line allow LISSMAC to offer their customers the greatest possible labour saving and highly precise cutting technology.

- Perfect for porous concrete and usable under some conditions for bricks
- Optimally dimensioned saw belt rolls guarantee a high service life of the saw belt
- Direct drive saw belt wheels reduce maintenance work on V-belts or other drive elements
- No risk of jamming – a generous opening in the lower saw roller box enables the debris to pass easily
- Constant, optimum tensioning using an automatic saw belt tensioner for optimum cutting accuracy and reduced risk of saw band breakage
- Short saw band changing times – with quick-coupling, the saw table can be opened with one hand movement
- Automatic saw belt cut-off – no excessive saw belt loading, since the saw belt only runs if it is actually sawing
- The wheel set allows the band saw to be moved easily by one person



1.1. Basics of intended use

1.1.1	The warranty obligation of the manufacturer and supplier is voided for improper or non-intended use. Any change to the machine which is not carried out by the manufacturer is prohibited. Changes, removal or addition of parts only with the written approval of the manufacturer.
1.1.2	The machine is constructed according to the state of the art and recognised technical safety rules. However, danger to life and limb of the user or third parties, and/or damage to the machine or other property may still arise from its use.
1.1.3	Only use the machine in technically faultless condition and for intended use, aware of safety and danger complying with the operating manual. You should particularly handle malfunctions which can compromise safety immediately, or have them addressed by experts.
1.1.4	<p>The LISSMAC cellular concrete band saw belongs to the masonry machines and is designed exclusively for cutting large-sized masonry stones. Cutting includes masonry stones made of porous concrete and perforated bricks in dry cut within the adjustable operating range. Use with perforated bricks is only possible to a limited extent, as the composition is different depending on the manufacturer. For hard perforated bricks, the wear on the saw belt is too great and thus not recommended. The masonry stone must lie flat against the stop on the saw table and must not be additionally held manually.</p> <p>Intended use also includes compliance with the operating manual and observance of inspection and maintenance manual. The manufacturer/supplier assumes no liability for damages caused by failure to comply with the intended use.</p>
1.1.5	<p>Foreseeable misuse / non-intended use:</p> <ul style="list-style-type: none">• Cutting wood, plastic or metal• Free hand-guided cutting• Any constructional changes, which change the safety or the type of design
1.1.6	The safety of this cellular concrete band saw is only guaranteed if LISSMAC- saw belts are used.

1.2. Organisational measures

1.2.1	This operating manual must be easily accessible for each person at the location of use.
1.2.2	<p>All additions to the operating manual, all generally valid legal and otherwise binding regulations for accident prevention and environmental protection are to be followed and instructed!</p> <p>Such obligations may also apply, for example, to the handling of hazardous materials or the wearing of personal protective gear or traffic regulations.</p>
1.2.3	Personnel assigned to jobs must have read and understood the operating manual, particularly the Safety Instructions chapter, before starting work. In the middle of work it is too late. This particularly applies to personnel who only work occasionally, such as those involved in tooling and maintenance.
1.2.4	At least occasionally, perform checks for safe and hazard awareness work by operators while following the operating manual!
1.2.5	Use personal protection equipment if necessary or required by regulations!
1.2.6	Observe all safety instructions and danger warnings and keep them in legible condition! Replace safety and danger instructions that are damaged or non-readable any more.

1.2.7	For safety-related changes to the machine or the running behaviour, stop the machine immediately and mark it accordingly. Report the problem to the responsible post/person!
1.2.8	No changes, removal or addition of parts without the written approval of the manufacturer! The instructions of the tool maker must be followed.
1.2.9	Only use tested original replacement parts from the manufacturer!
1.2.10	Observe required or prescribed deadlines given in the operating manual for inspection. A yearly inspection by an expert is required. Before the inspection, the machine must be cleaned thoroughly. Also, the power plug must be disconnected before any maintenance or repair work.
1.2.11	Follow all setup, maintenance, and inspection activities and schedules prescribed by the operating manual, including all information about the replacement of parts / assemblies! These activities may only be carried out by experts.
1.2.12	Inform operating personnel before beginning special and maintenance work! Name a supervisor!
1.2.13	Workshop equipment suitable for the work is absolutely necessary for performing maintenance actions.

1.3. Personnel choice and personnel qualification; basic responsibilities

1.3.1	Only qualified personnel 18 years of age or older may operate the masonry saw independently. All persons must be trained in the operation.
1.3.2	Establish responsibilities of the personnel for operating, changeover, servicing, and repairing the machine!
1.3.3	Make sure that only authorized personnel works at the machine.
1.3.4	The operator must wear personal safety equipment according to the safety regulations, such as safety shoes, safety gloves and safety glasses.
1.3.5	Remaining by the running machine unnecessarily is prohibited! Direct unauthorised personnel, who are not working on the machine, away from the work area. Block off the working area, if necessary.
1.3.6	Work on the electrical equipment of the machine may only be carried out by qualified electricians or trained personnel under the management and supervision of a qualified electrician, and in accordance with the rules of electronics.
1.3.7	Any personnel training, learning, being instructed, or currently involved in general education may only work with the machine under the continual supervision of an experienced person!

1.4. Safety instructions and residual risks for the operation phases of the machine

1.4.1. Transport, assembly and installation

1.4.1.1	Transport, assembly and installation on/with the cellular concrete band saw may only be carried out in transport position.
1.4.1.2	Lift the machine only according to the instructions in the operating manual and with proper lifting gear! Observe the attachment points (crane eyes) for load lifting system.
1.4.1.3	Transport in compliance with the maximum operating weight, this should be exclusively done by crane. When moving the machine only for a short distance the machine can also be pushed using the wheel set.
1.4.1.4	Even when moving the machine only for a short distance, disconnect the machine from the power source! To recommission the machine, it must be connected properly to the power supply.

1.4.2. Moving the cellular concrete band saw

1.4.2.1	The cellular concrete band saw may only be moved with the saw belt at a standstill and the drive motor turned off. Disconnect the machine from the power source!
1.4.2.2	Before leaving the operating position, the electric motor must be shut down and the saw belt must no longer rotate. There is a danger of injury on the saw belt.

1.4.3. Commissioning

1.4.3.1	The commissioning of the machine may only be carried out in transport position.
1.4.3.2	Make sure that the foundation meets the load carrying capacity. All obstacles must be cleared away from the working area and make sure there is sufficient lighting.
1.4.3.3	When inserting the saw belt, observe the running direction. There is a danger of injury on the saw belt.
1.4.3.4	Visual inspection for damages and defects. Special check of the safety equipment and the saw belt.
1.4.3.5	The safety of the cellular concrete band saw is only guaranteed if tested LISSMAC saw belts are used.
1.4.3.6	It is forbidden to connect the machine to the power mains without GCFI protection in the mains supply line or the junction box.
1.4.3.7	The condition of the saw belts must be checked daily before starting the cutting operation. Cracked saw belts must be replaced immediately.

1.4.4. Operation

1.4.4.1	Refrain from working in any manner that is questionable in regard to safety!
1.4.4.2	Take measures to ensure that the cellular concrete band saw is only operated in a safe, functional condition!
1.4.4.3	At least once per shift check the machine for externally recognisable damage and deficiencies! Any changes which occur (including operating behaviour) must be reported immediately to the responsible post/person! If necessary, immediately stop the machine and secure it against restart!
1.4.4.4	Immediately stop and secure the machine in case of malfunctions! Immediately correct malfunctions! Electrical work may only be carried out by qualified electricians.
1.4.4.5	Any contact with the rotating saw belt is prohibited.
1.4.4.6	If the saw belt tears, first wait until the saw belt stops before opening the side doors.
1.4.4.7	Cutting curved or uneven workpieces is only allowed if the workpiece lies flatly between the saw table and stop, has a secure guide and must not additionally be held with the hands.
1.4.4.8	The cellular concrete band saws may only be operated by one person and is limited by proper positioning at the rear part of the cellular concrete band saws. Any other use or use above and beyond is not considered intended use.
1.4.4.9	Do not pull the power plug from the power source when power is on.
1.4.4.10	Reaching into the saw belt during cutting is prohibited. These works may only be carried out with the saw belt at a standstill and the drive motor turned off.
1.4.4.11	After finishing work the saw belt must be released to take the tension off the bearings of the saw belt wheels. Before starting work the saw belt must be tightened again.

1.4.5. Blockage of the cellular concrete band saw

1.4.5.1	When the saw belt is blocked the machine must be switched off immediately.
1.4.5.2	Check the saw belt, saw belt wheels and the rubber coating on the saw belt wheels for damage.

1.4.6. Special work while using the machine

1.4.6.1	Follow all setup, maintenance, and inspection activities and schedules prescribed by the operating manual, including all information about the replacement of parts / assemblies! These activities may only be carried out by technical personnel.
1.4.6.2	Inform operating personnel before beginning special and maintenance work! Name a supervisor!
1.4.6.3	If the machine is completely turned off during maintenance and repair work, it must be secured against unexpected application of power.
1.4.6.4	Before cleaning the machine with water or other cleaning agents, cover/glue all openings in which no water/cleaning agent should penetrate due to safety and/or functional reasons. Electric motors, switches and plugs are especially at risk. After cleaning, remove the covers/tape completely.
1.4.6.5	During service and repair work, always tighten again loose bolt joints.
1.4.6.6	If dismantling is required for fitting, servicing and repair, the safety fittings must be remounted and checked immediately following the service and repair work!
1.4.6.7	Please ensure the safe, environmentally friendly disposal of operating and auxiliary materials and replacement parts!

1.5. Safety instructions for special types of dangers

1.5.1. Danger for the operator by the machine

1.5.1.1	Working on the cellular concrete band saw and moving with rotating saw belt is prohibited.
1.5.1.2	The electric motor of the cellular concrete band saw must only be put in operation for intended use cutting.
1.5.1.3	Never clean the running saw belt holding a brush or scraper in the hand. Switch off the machine and then clean it.

1.5.2. Electric power

	1.5.2.1	Use only original fuses with the specified current rating! In case of malfunctions, turn off the cellular concrete band saws immediately! Electrical work may only be carried out by technical and qualified personnel.
	1.5.2.2	The machine's electrical equipment must be inspected/checked regularly. Faults such as loose connections or damaged cables must be corrected immediately. The machine must be labeled so that it cannot be started by others.
	1.5.2.3	Carry out maintenance or repair work only when the machine is disconnected from the power mains.
	1.5.2.4	A voltage drop of more than 10% leads to damage of the electrical switches.

1.5.3. Dust

	1.5.3.1	When working in close quarters, follow any applicable national guidelines!
	1.5.3.2	The cellular concrete band saw can be equipped for use in interior areas with a dust extraction.

1.5.4. Noise

	1.5.4.1	Noise value (see 2.4)
--	---------	-----------------------

1.6. Transport

	1.6.1	Name expert instructors for the lifting process
	1.6.2	Only use suitable transport vehicle with sufficient load capacity!
	1.6.3	Secure loads reliably according to the regulations. Use suitable attachment points!
	1.6.3	Lift the machine only according to the instructions in the operating manual and with proper lifting gear! Observe the attachment points (crane eyes) for load lifting system.
	1.6.3	Even when moving the machine only for a short distance, disconnect the machine from the power source! Before restarting the machine, connect it to the power mains correctly!
	1.6.4	When recommissioning, follow the operating manual!
	1.6.5	Transport of the cellular concrete band saw may only be carried out in transport position.

1.7. Packaging and Storage

To ensure sufficient protection during shipping and transport, the machine and its components are carefully packaged. When receiving the machine, the machine should be checked for damage. The packaging of the device consists of materials which can be recycled. Put these by type into the relevant recycling containers, so that they can be recycled properly.

In the case of damage, the machine must not be put into operation. Even damaged cable and plugs represent a safety risk and must not be used. In this case, please contact the manufacturer.

If the machine is not immediately put into operation after unpacking, it must be protected from moisture and dirt. Tools that are not used must be protected from moisture. The applied segments around the saw belt must be protected from damage.

1.8. Environmental protection

Packaging material, cleaning agents, used or residual operating materials, as well as removed wear parts, such as drive belts or motor oils must be taken to recycling corresponding to the valid regulations for environmental protection at the place of use.

1.9. Disposal

If the expiry date of the device has been reached, in particular if functional errors happen, make the used machine unusable.

Dispose of the device according to the valid regulations for environmental protection of your country. Electrical waste may not be disposed of in household waste. Take the used device to a central rubbish collection centre.

2. DESCRIPTION OF THE DEVICE

2.1. Name of machine parts

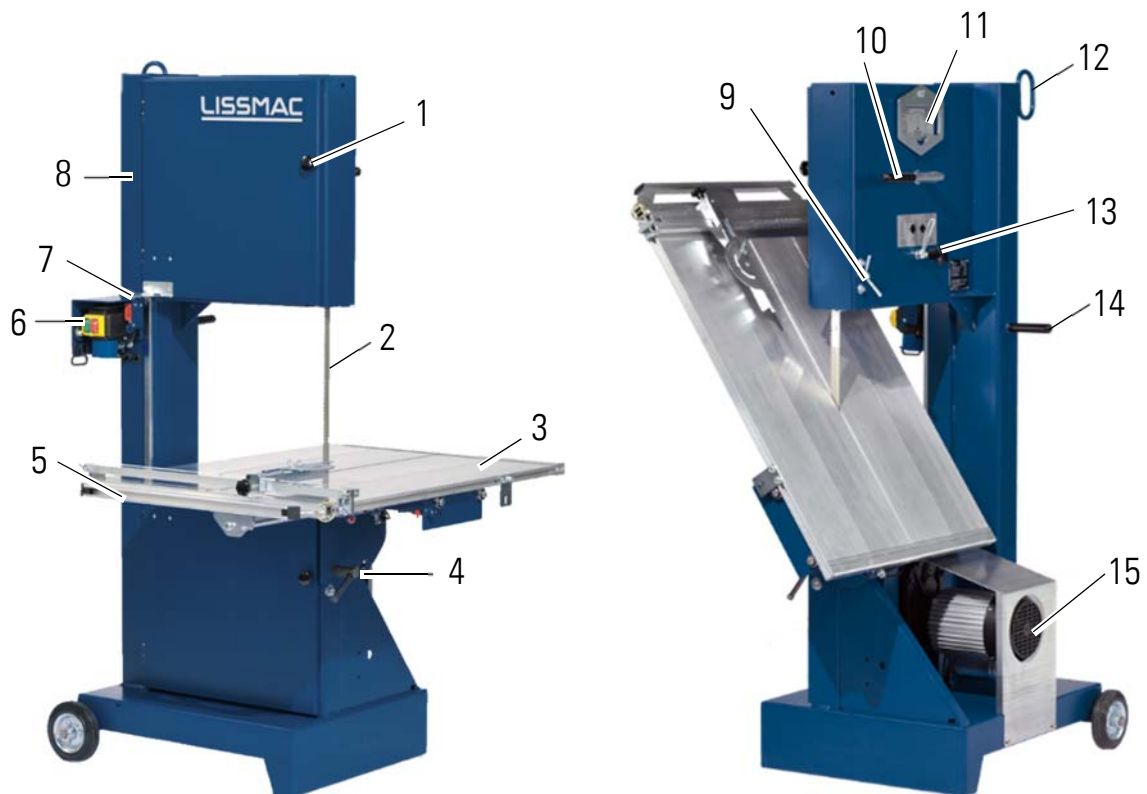

Pos. 1	Side door with rotary knob	Pos. 9	Saw belt protection clamping lever
Pos. 2	Saw belt	Pos. 10	Tensioning lever for saw belt
Pos. 3	Saw table	Pos. 11	Crane eye
Pos. 4	Saw table clamp screw	Pos. 12	Handle eyes
Pos. 5	Handle on saw table	Pos. 13	Adjustment of saw blade
Pos. 6	Power supply ON/OFF	Pos. 14	Handle to shift
Pos. 7	Safety switch	Pos. 15	Drive motor
Pos. 8	Frame		

2.2. Safety guards

Pos. 1	Side door with rotary knob
Pos. 6	Power supply ON/OFF
Pos. 7	Safety switch
Pos. 9	Saw belt protection clamping lever

2.3. Technical data

	MBS 510			MBS 650		MBS 760
Motor output	1,5 kW	1,5 kW	1,1 kW	1,5 kW	1,1 kW	1,1 kW
Power consumption	20 A	12,5 A	2,7 A	12,5 A	2,7 A	2,7 A
Connection values	110 V	230 V	400 V / 16 A	230 V	400 V / 16 A	400 V / 16 A
Protection class	IP 55					
Cutting height max.	515 mm			650 mm		760
Cut length	700 mm					
Dimensions (LxWxH)	1080 x 1050 x 1840 mm			1080 x 1050 x 1975 mm		1560 x 985 x 2215 mm
Maximum operating weight	173 kg			175 kg		367
Saw table load carrying capacity	50 kg					200 kg
Max. dimension of the workpiece to be cut	500 400 515			500 400 650		500 400 760

Änderung der technischen Daten ohne vorherige Ankündigung.

2.4. Noise power level



Danger!

In an environment with a high noise level, for example when working near loud machinery, wearing hearing protection in the workplace is prescribed for above 85dB(A).

The details define volume of noise level, related to the operator workspace and the noise power level of the cellular concrete band saws.

	Noise power level LwA Measurement unit 2.5 dB	Workplace related emissions noise level LpA Measurement safety factor 4 dB
Porous concrete	101.8 dB(A)	83.8 dB(A)

The workplace related emissions value is based on an eight hour work shift and reduces correspondingly with shorter exposed time.

The values are determined by the noise emission measurement.
Testing is done without load with the largest permitted saw belt of the cellular concrete band saws.

Measurement tolerances:
2.5 dB for the A-value noise power level
4 dB for the A-value emission noise pressure level

Emission noise pressure is done in compliance with the standard directive 2000/14/EC.

3. COMMISSIONING

3.1. Connections and operating materials

Connection of electricity

A reliable power source with an operating voltage and corresponding fuses as shown on the model plate must be available. Supply lines must not be damaged.
A voltage drop of more than 10% leads to damage of the electrical switches!

Lubrication points

Moving parts must be lubricated on the lubrication points at regular intervals. The manufacturer uses a qualified heat-resistant multi-purpose grease.

3.2. Setting up the cellular concrete band saw

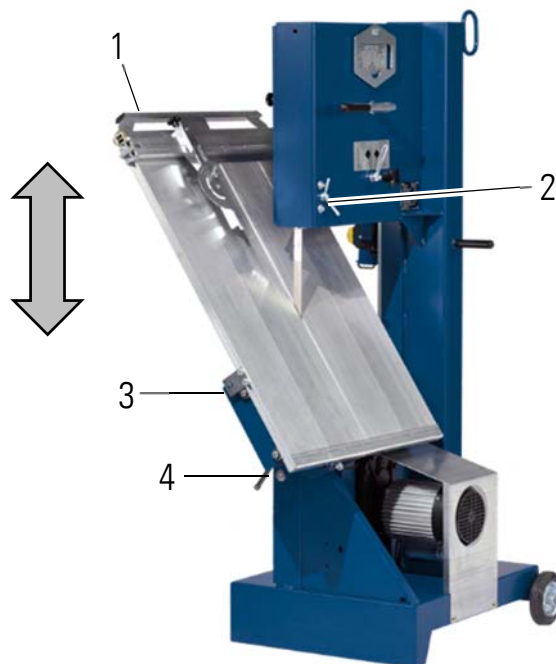

Note

The cellular concrete band saws are packaged on a pallet for delivery. The packaging and pallet must be removed before the first commissioning.

- The cellular concrete band saws must stand cleanly on the floor when set up and must not tip. Check secure positioning before commissioning
- Hold the saw table (Pos. 1) on the handle, at the same time unscrew the clamp screw (Pos. 4) and put the saw table in the horizontal position
- Tighten the clamp screw (Pos. 4) under the saw table
- Release the saw table lock using the spring lock (Pos. 3)
- Set the saw belt protection (Pos. 2) to the total height of the masonry stone being cut

3.3. Running direction of the saw belt (only 400 V)

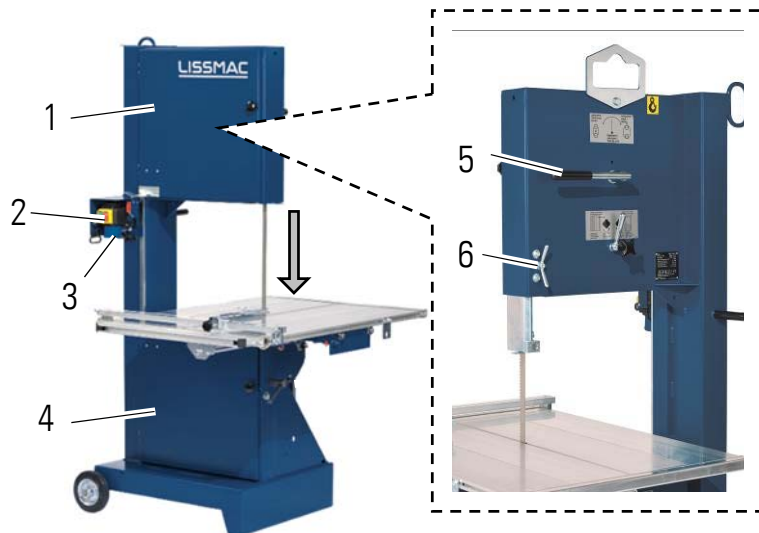

- Close both side doors (Pos. 1 und 4)
- Tighten the saw belt with the tensioning lever (Pos. 5)
- Place the saw belt protection completely down using the clamping lever (Pos. 6)
- Put the power supply cable in the socket (Pos. 3)
- Activate the switch (Pos. 2) briefly in jog mode and check the running direction of the saw belt (teeth must run from top to bottom!)

3.3.1. Changing running direction of the saw belt



- Unplug the power supply cable
- Turn the phase of the socket with a screwdriver

3.4. Check distance between saw belt and guide rollers

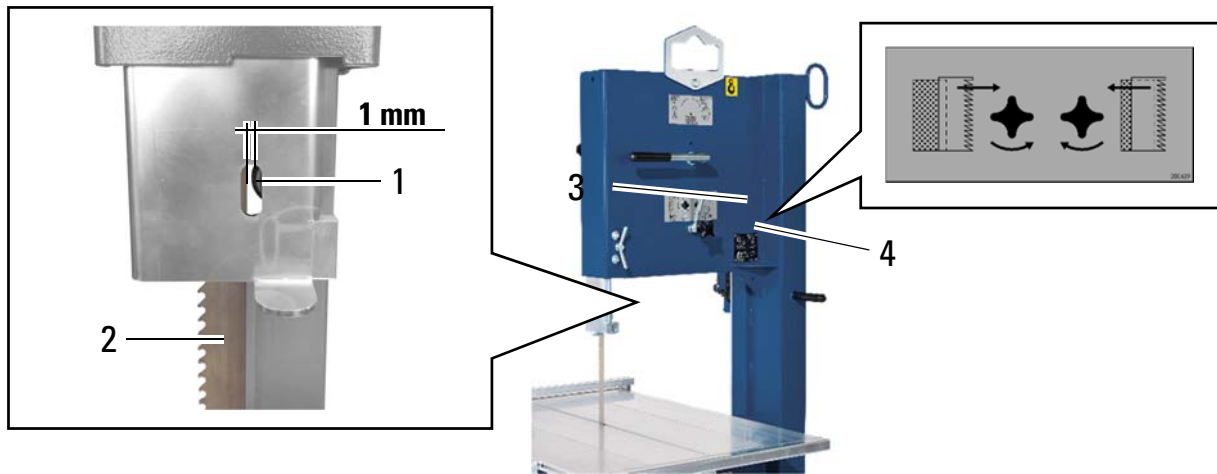

- Switch off cellular concrete band saws
- Open side doors
- Check the distance between the saw belt (Pos. 2) and guide rollers (Pos. 1)



Note

In standstill the distance between the saw belt (Pos. 2) and guide rollers (Pos. 1) must be approx. 1 mm.

Changing the distance

- Open clamping lever (pos. 3)
- Release the clamping lever (Pos. 3) and turn on star handle (pos. 4)
Turn to the right - distance becomes smaller
Turn to the left - distance becomes larger
- Tighten the position via the clamping lever (Pos. 3)



Danger!

Before the current position of the saw belt is tested the side doors must be closed!

- Briefly switch on the cellular concrete band saw (job mode!)
- Check the distance between the saw belt (Pos. 2) and guide rollers (Pos. 1)
- Repeat process until the distance is correct

3.5. Preparing to Start and Setting Operating Range

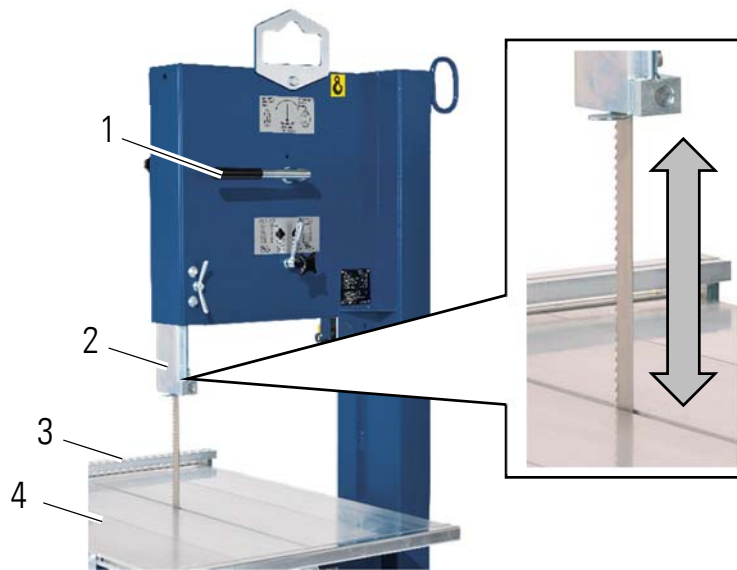

During the preparation of the saw the following steps must be completed:

- Both side doors are closed and locked
- Power source is connected on the main switch
- Saw belt is tightened via the tensioning lever (Pos. 1)
- Place the masonry stone to the stop (Pos. 3) on the saw table (Pos. 4)
- Adjust the saw belt protection (Pos. 2) on the masonry stone



Note

The saw belt protection (Pos. 2) must be placed as tight as possible on the masonry stone to keep the operating range as small as possible.

3.6. Setting up the cellular concrete band saw 760

**Caution!**

Both support feet (pos. 3) must be extended and adjusted to the floor to stabilize the cellular concrete band saw 760.

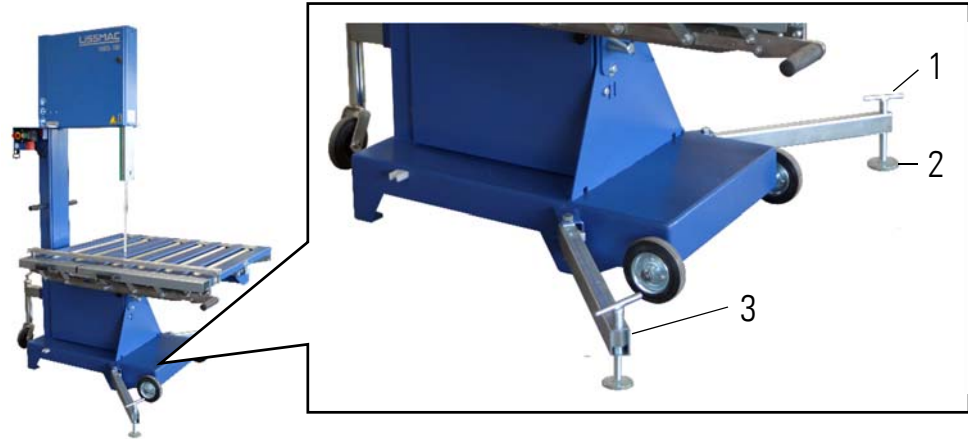

- Release both support feet (pos. 3) from their catches and fold them up to the stop
- Rotate the adjuster (pos. 1) until the base plate (pos. 2) is placed on the floor

4. TRANSPORT

4.1. Transport position



Note

Transport with the forklift is prohibited!



Included in the transport setup of the cellular concrete band saw:

- Power source is disconnected
- Side doors are closed
- Saw table is secured via the spring lock
- Saw belt protection is moved completely up
- Saw table is folded up and the clamping screw is tightened
- Saw belt is tightened

4.2. Move with the crane



Danger!

Only use undamaged slinging equipment with sufficient carrying capacity. Personnel should never remain under hanging loads.

- Use hoisting gear of sufficient load capacity
- Name expert instructors before the lifting process
- Hang the cellular concrete band saw on the swivelling crane eye (Pos. 1)
- Only use suitable transport vehicle with sufficient load capacity
- Always keep an eye on the cellular concrete band saw when moving

4.3. Moving the cellular concrete band saws



- Place the left foot on the edge (Pos. 3) of the cellular concrete band saws
- The left hand grasps the handle (Pos. 2)
- The right hand the eye (Pos. 1)
- Carefully tip the cellular concrete band saws back and push using the wheels

4.4. Transport of cellular concrete band saw 760



Note

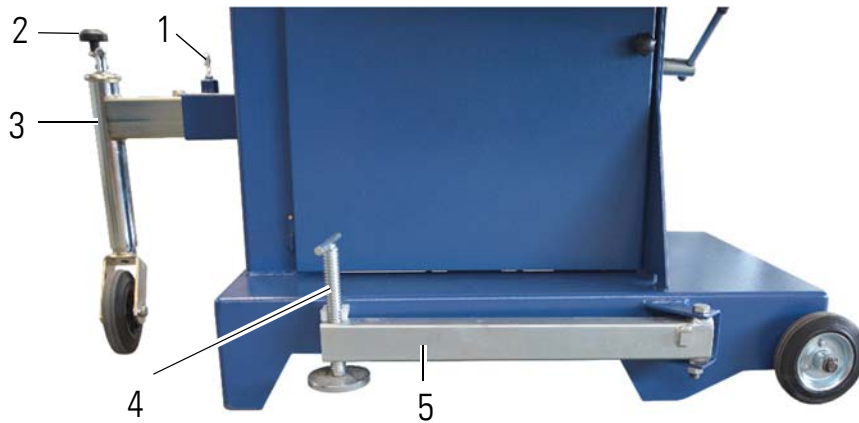

The support wheel must be used when transporting the cellular concrete band saw 760. After moving, the cellular concrete band saw must be lowered using the support wheel.





- Clip the support feet (pos. 5) into the catches and turn the adjustment (pos. 4) upward to the stopper.
- Push the support wheel (pos. 4) into the guide and secure using the hook (pos.1)
- Lift the cellular concrete band saw using the lever (pos. 2)
- Pull the hook (pos. 1) and remove the support wheel (pos. 4)

5. OPERATION

5.1. Safety



 Note	The cellular concrete band saws may only be put into operation, if all starting preparations (see 3.5) are met. If this is not possible, the operation of the cellular concrete band saws is prohibited.
 Note	The authorised operator must guide the feed movement when cutting using the saw table. Standing is limited to this area of the cellular concrete band saws. The machine may only be operated by one person.

5.2. Cutting with the cellular concrete band saw

 Danger!	Opening of the side doors or reaching into the rotating saw belt during cutting is prohibited. These works may only be carried out with the saw belt at a standstill and the drive motor turned off.
 Note	Observe the intended use of the cellular concrete band saw!



- Place the masonry stone on the saw table (Pos. 2) to the stop
- Switch on the cellular concrete band saw via the main switch (Pos. 1) and wait until the drive motor has reached its complete speed
- Guide the feed movement for cutting the masonry stone slowly using the handles (Pos. 3). The cellular concrete band saw switches off after cutting through the masonry stone

 Danger!	Cleaning the machine while running is prohibited! To clean, switch off the machine and wait until the saw belt no longer turns. Never clean with a brush or a scraper in the hand if the saw belt is still running.
 Caution!	If the saw belt tears, first switch off the machine and wait until the saw belt stops before opening the side door.
 Note	After finishing work the saw belt must be released to take the tension off the bearings of the saw belt wheels. Before starting work the saw belt must be tightened again.

5.3. Replacing the saw belt

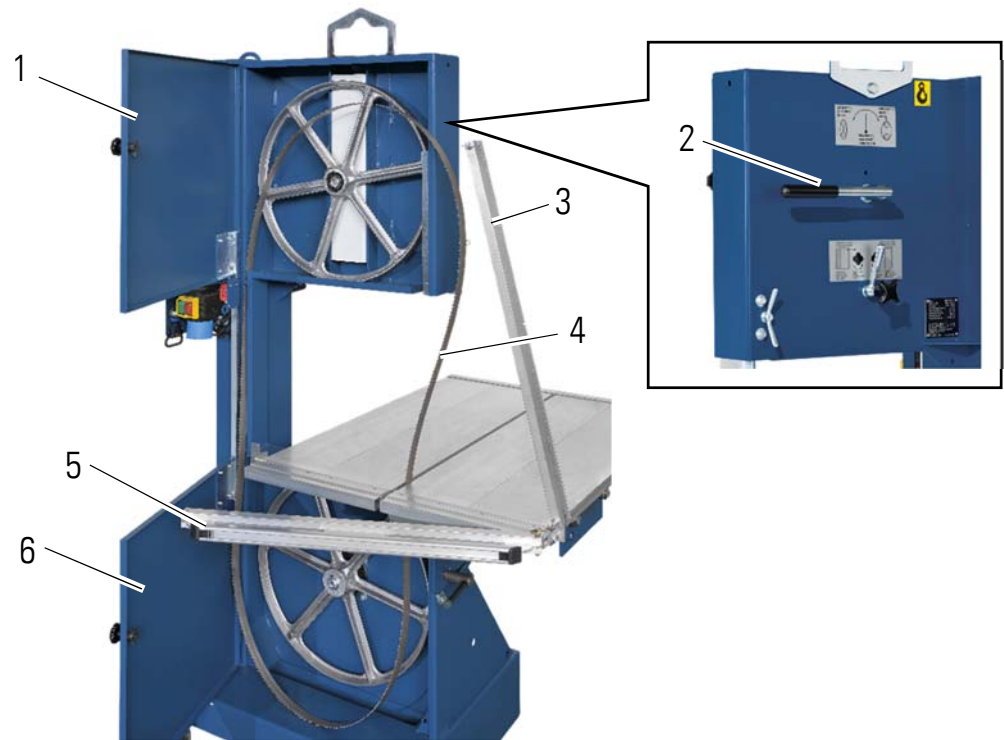

- Disconnect the cellular concrete band saw from the power source
- Flip up the scale tube (Pos. 3)
- Open the table bracket on the handle (Pos. 5) and remove the cotter pin on the left side (Pos. 5) from the handle and fold the handle away towards the outside
- Release the saw belt via the tensioning lever (Pos. 2)



Caution!

When the saw belt is released the side doors must be opened carefully. When removing the saw belt there is a risk of injury - wear protective gloves!

- Carefully open the side doors (Pos. 1 and 6)
- Remove the saw belt (Pos. 4) from the cellular concrete band saw

Installing the new saw belt:



Note

The condition of the saw belt must be checked before each operation. Cracked saw belts must be replaced immediately.

- The saw belt must lie cleanly in the running guides of the saw blade wheels
- Teeth point downward on the table (teeth must run from top to bottom!)
- Check distance between saw belt and guide rollers (see 3.4)

5.4. Workpiece blockage

**Caution!**

When the saw belt is blocked the machine must be switched off immediately.

- Remove the saw belt and check the condition
- Check the saw belt wheels and the rubber coating on the saw belt wheels

5.5. Selection of the tools

**Caution!**

Damaged saw belts must not be used!

Storage of tools

The used tools must be protected by moisture. The applied segments around the saw belt must be protected from damage.

The safety of this cellular concrete band saw is only guaranteed if LISSMAC- saw belts are used.

Service life of the tools

The service life of the saw belt depends on the feed force during cutting.

If there is a feed force on the saw belt that is too strong, the saw cut runs off and the saw belt warps. The distance between the saw belt and the guide roll must be set correctly (see 3.4).

Disposal of the tools

Used or faulty tools must be sent to recycling corresponding to the applicable regulations at the location of use for protection of the environment.

6. CLEANING

**Danger!**

Cleaning the machine while running is prohibited!

To clean, switch off the machine and wait until the saw belt no longer turns. Never clean with a brush / scraper in the hand if the saw belt is still running.

To protect painted surfaces no aggressive cleaning agents may be used.

- Shut off the machine and disconnect the power connection from mains power
- Side doors can be opened for cleaning the machine

7. DISMANTLING

- Disconnect the power connection from the mains power
- Put the cellular concrete band saw into transport position (see 4.1)

8. MAINTENANCE

8.1. Service



Danger!

Maintenance and repair works must only be carried out by qualified personnel. These works may only be carried out with the saw belt at a standstill and the drive motor turned off.



Danger!

Cellular concrete band saws must be secured against turning on by other people. Maintenance and repair works may only be carried out when the machine is turned off.

	daily	weekly	monthly	as required
Visual inspection for recognisable damage and deficiencies	•			
Control of the safety equipment	•			
Control of the saw belt	•			
Releasing tension on saw belt	• acc. to use			
Clean cellular concrete band saws	•			
Lubricate the lubrication points			•	
Screw connections	Retighten all screw connections after 20 operating hours			

8.2. Lubrication points



Danger!

Maintenance and repair works must only be carried out by qualified personnel. These works may only be carried out with the saw belt at a standstill and the drive motor turned off.



Note

Only use quality lubricant with the specified requirements. The lubricant used is called "Energrease LS2 BP".

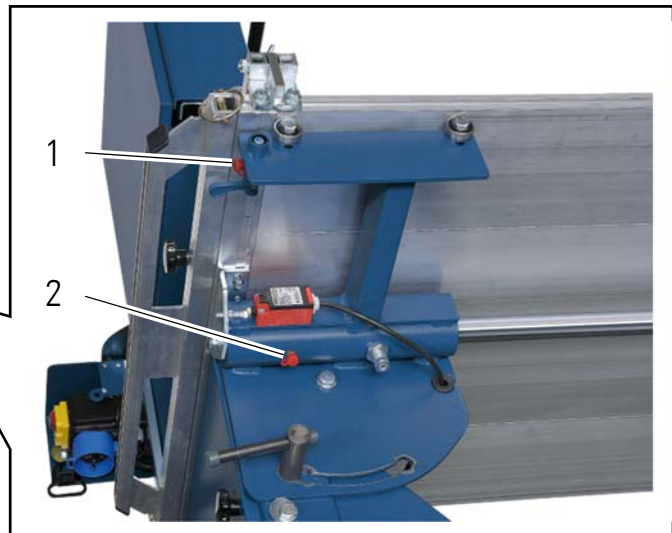

Lubrication points on the cellular concrete band saw:

- Spring lock (Pos. 1) for locking the table
- Guide sleeve (Pos. 2) under the saw table

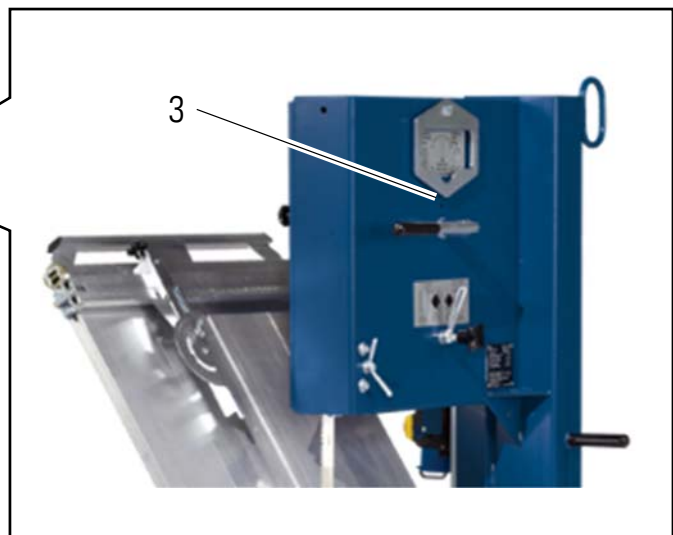

- Lubricate the automatic power chuck above the opening (Pos. 3) on the tensioning lever with a spray oil

8.3. Troubleshooting table



Danger!

Pull the power plug before any maintenance or repair work. Measures must be taken, so that an accidental start-up by others is not possible. Maintenance and service works may only be carried out by qualified personnel.

Error	Cause	Remedy
Motor does not run	Mains cable faulty	New mains cable
	Switch faulty	May only be corrected by an electrician!
	Motor faulty	
Low cutting performance	Feed too fast	Cut with slower feed
	Saw belt dull	Replace saw belt
Saw blade tilted / blocked	Hooked in the stone	Disconnect the saw from power. Open doors, move saw belt backwards, pull the teeth out of the workpiece



Note

If the feed force is too large, the following points must be checked:

- Saw belt dull or defective?
- Saw belt selection correct?
- Full power or rotation speed from the electric motor?

8.4. Torque of screw connections

Strength class:	8.8	10.9	12.9
Dimensions	Max. tightening torque in Nm	Max. tightening torque in Nm	Max. tightening torque in Nm
M4	3.3	4.8	5.6
M5	6.5	9.5	11.2
M6	11.3	16.5	19.3
M8	27.3	40.1	46.9
M10	54	79	93
M12	93	137	160
M14	148	218	255
M16	230	338	395
M18	329	469	549
M20	464	661	773
M22	634	904	1057
M24	798	1136	1329
M27	1176	1674	1959
M30	1597	2274	2662

9. WARRANTY

The warranty for this machine is 12 months. For the following listed wear parts the warranty only applies if the wear is not caused by operation.

Wear parts are parts that with intended use of the machine have limited operational wear. The wear time is not uniformly specified, it differs according to intensity of use. Wear parts are device specific and are to be maintained, adjusted and if required exchanged according to the manufacturers' operating manual.

Wear caused by operation does not qualify for warranty claims.

- Feed and drive elements, such as toothed racks, gears, pinions, spindles, spindle nuts, spindle bearing, cables, chains, chain wheels, belts
- Seals, cable, hoses, collars, connectors, couplings and switches for pneumatics, hydraulics, water, electrical, fuel
- Guide elements, such as guide strips, guide bushings, guide rails, rollers, bearings, anti-slide plating
- Tension elements from quick-coupling systems
- Flushing head seals
- Plain and roller bearings, which do not run in oil bath
- Shaft sealing rings and sealing elements
- Friction and overload couplings, braking equipment
- Carbon brushes, collectors
- Easily dissolvable rings
- External potentiometer and manual switching elements
- Fuses and lamps
- Auxiliary and operating materials
- Fastening elements, such as pegs, anchors and screws
- Bowden cables
- Lamella
- Diaphragms
- Spark plugs, glow plugs
- Parts of reversing starters, such as crank cable, crank handle, crank roller, crank spring
- Sealing brushes, sealing rubber, splash guard cloths
- All types of filters
- Drive and deflector rollers and bracings
- Cable laying protection elements
- Running and drive wheels
- Water pumps
- Cut goods transport rollers
- Drilling, separating and cutting tools
- Transport belt
- Rubber scrapers
- Needle felt protection
- Energy storage

10. SPARE PARTS LIST MBS 510 & 650

Item	Item no.	Designation	Specification	Units	Spare part Recommendation
2	680851	DOOR LOCK, ASSY			X
2.1		KNURLED STAR HANDLE FOR DOOR LOCK		1	
2.2		SPRING WASHER	DIN 137 8.4	1	
2.3		SPACER SLEEVE FOR DOOR LOCK	PE 16x8.2x6	1	
2.4		DOOR LOCK		1	
2.5		SPLINT	DIN 94 3.2x36	1	
14	690041	SAW BELT WHEEL (TOP)			X
14.1		WHEEL	D = 45 mm	2	
14.2		BALL BEARING	6205 2RS B-BEARING	2	
14.3		SPACER (ALU WHEEL TOP)		1	
14.4		LOCKING RING	DIN 472 52	2	
24	680084	CLAMPING LEVER SAW BELT, ASSY			X
24.1		DISC	DIN 125 A 21.0	1	X
24.2		SPRING PIN	ISO 8748 6x30 SPI	1	X
24.3		TENSIONING FIXTURE		1	X
25		HANDLE PVC	LISSMAC	2	X
33	680005	BELT GUIDE, ASSY			X
33.1		SAW BELT GUIDE		1	
33.2		SAW BELT GUIDE ROLL, INDIVIDUAL		1	
42	1006827	WHEEL SET CPL.			X
42.1		DISC	DIN 125 A 21.0	2	X
42.2		SPLINT	DIN 94 4.0x45	2	X
42.3		SOLID RUBBER WHEEL	160/40 F. MBS	2	X
50	690034	SCALE, ASSY.			X
50.1		COUNTERSUNK HEAD SCREW	DIN 7991 8x60	1	
50.2		STEEL WASHER	DIN 125 A 8.4	1	
50.3		LOCKING HEXAGON HEAD SCREW	BIW V-FORM 8.0	1	
50.4		WING SCREW	DIN 316 6x25	1	
50.5	690034	SCALE (ALU PIPE)		1	X
55	690007	TABLE, ASSY			X
51.1		SCALE HOLDER, LEFT		1	
51.2		DISC	DIN 125 A 8.4	2	
51.3		LOCKING HEXAGON HEAD SCREW	8x20	2	
51		SCALE HOLDER, RIGHT		1	
52		SLOTTED NUT	18/18x6 M 8.0	6	
53		FOLDING SPLINT	8x41x47 mm	1	X
54		TABLE BRACKET	710 mm	1	
55.1		TABLE		1	X
56		PLATE FOR TABLE		1	
79		SLIDE STOPPER	30x20 45GR.	2	

Item	Item no.	Designation	Specification	Units	Spare part Recommendation
67	680010	CLAMPING LEVER, ASSY.			X
67.1		COVER CAP	12 mm	2	
67.2		TOGGLE		1	
67.3		CENTRING PIN		1	
70	680524	RUNNING ROLLER		4	X
1	690813	DOOR, BOTTOM		1	
6	690005	DOOR, TOP		1	
7	280223	WELD-ON BELT ROLL WITH WASHER		3	
7.1	360129	HEXAGON SOCKET SCREW	M6x60	1	
7.2	300833	LOCK NUT	M6	1	
10	300119	LOCKING RING	DIN 471 25	1	
14.1	203034	WHEEL	D = 45 mm	2	
15	203013	RUBBER RING FOR SAW BELT WHEEL	1375x24x3 mm	2	
16	799598 799505	CARBIDE TIPPED SAW BELT CARBIDE TIPPED SAW BELT	MBS 510 3.750x27 MBS 650 4.020x27	1	X
17	690013	CLAMPING ELEMENT		1	
18	603055	CLAMPING PIECE		1	
18.1	300237	DISC	DIN 9021 8.4 VZ	2	
18.2	300128	LOCKING HEXAGON HEAD SCREW	8 X 12 VZ.	1	
18.3	300140	CLAMPING WASHER	KS 10	1	
18.4	300177	DISC	DIN 125 A 10.5 VZ.	1	
19	680106	CLAMPING PIN+ CLAMPING WASHER		1	
20	203020	PRESSURE SPRING	150x30x6.5	3	
21	603056	PRESSURE PLATE		1	
22	690033	ECCENTRIC		1	
23	201575	CYLINDER BUSH	2023 -20	1	
25	211416	HANDLE PVC	LISSMAC	2	X
26	203012	STAR KNOB FOR WHEEL ADJUSTMENT		1	
27	203024	CONICAL KNOB FOR WHEEL ADJUSTMENT		1	
27.1	300166	DISC	DIN 125 A 13.0 VZ.	1	
28	202574	CLAMPING NUT	M8	1	
28.1	300237	DISC	DIN 9021 8.4 VZ	1	
29	603309	CLAMPING RAIL		1	
30	300556	CARRIAGE BOLT	DIN 603 8x45 VZ	1	
31	1005587	HAND PROTECTION		1	
32	603311	CLAMPING PLATE		1	
35	603061	BELT GUIDE HOLDER		1	X
35.1	300388	SET SCREW	DIN 916 8x16 VZ	1	
36	603113	SWIVEL PIN		2	
36.1	300874	HEXAGON HEAD SCREW	DIN 965 4x 6 VZ	2	
36.2	300559	LOCKING HEXAGON NUT	BIW V-SHAPE 12.0 VZ	2	
36.3	300166	DISC	DIN 125 A 13.0 VZ.	2	
37	201576	CYLINDER BUSH	KU 2528-20	2	
38	360096	PARALLEL KEY	DIN 6885 A 8x 7x 18	1	
39	400006 400399	GEAR MOTOR 230 V GEAR MOTOR 400 V	230V 1.5KW 223 RPM 400V 1.1KW 230 RPM	1	
39.1	403907	CONDENSER	25 M μ F	1	
39.2	208620 203026	FAN HOOD 230 V FAN HOOD 400 V		1	
39.3	403236	CABLE SCREW FITTING	ST-M 20X1.5 PVC	1	
without	208619	FAN BLADE 230V		-	

Item	Item no.	Designation	Specification	Units	Spare part Recommendation
figure					
without figure	203041	SPUR GEAR FOR GEAR MOTOR		-	
without figure	203042	HOUSING SEAL		-	
without figure	203043	FLANGE SEAL		-	
without figure	203008	FLANGE		-	
40	603065	SPACER (MOTOR)		1	
41	603059	SAW BELT WHEEL (BOTTOM) 30		1	
41.1	300127	LOCKING HEXAGON HEAD SCREW	10 X 40 VZ	1	
41.2	300344	DISC	DIN 440 11.0 VZ.	2	
44	692536 692537	FRAME MBS 510 FRAME MBS 650		1	
45	603062	MOTOR GUIDE PLATE		1	
46	680025	SIDE STOP, ASSY		1	X
without figure	203029	ALU-PROFILE	348 mm	-	
without figure	203028	ALU-PROFILE	707 mm	-	
without figure	280147	ALU-PROFILE	990 mm	-	
without figure	301167	SLOTTED NUT	18/18x6 M 8.0	-	
57	603052	TABLE HOLDER		1	
58	603058	GUIDE SHAFT (TABLE)		1	
59	300885	LOCKING RING 40		2	X
60	280188	WIPER RING	ASA 30-40-5/8-BL-BN	2	X
61	280022	BALL SLEEVE	KH 3050 B	2	X
62	603051	TABLE HOLDER 1, STRAIGHT		1	
63	300575	CAP - LUBRICATING NIPPLE	10x1 RED	1	
64	300040	LUBRICATION NIPPLE	10x1 H1 VZ	1	
65	200686	PRESSURE PIECE	M16	1	
66	300146	HEXAGON NUT	DIN 934 10.0 VZ	1	
66.1	300030	HEXAGON NUT	DIN 439 16.0 VZ	1	
71	690038	SWIVEL DEVICE		1	
71	1008270	SWIVEL DEVICE CPL		-	
72	603322	CRANE EYE		1	
73	404648 404649 681596 603124 681694 603124	ON/OFF SWITCH ON/OFF SWITCH ON/OFF SWITCH SWITCH ADAPTER PLATE ON/OFF SWITCH SWITCH ADAPTER PLATE	230V 400V 110V-50HZ 110V MBS 110V-60HZ 110V MBS	1	X
without figure	401154	PLUG FOR MBS	3X16A 230V BLUE	-	
74	400053	END SWITCH	I88-U1Z W M20	1	X
76	691662 690651	DOOR CONNECTOR MBS 510 DOOR CONNECTOR MBS 650		1	
77	603472	SWITCHING STOP		1	
77.1	300853	BLIND RIVET	DIN 551 8x70	2	
80	603471	LIMIT SWITCH PLATE, TOP		1	
81	402212	END SWITCH	T12-SU1Z RW 90° M16	1	X
83	400357	CABLE SCREW FITTING	PG 9, PA	2	
84	201125	PIPE CLAMP	RSGU 1.08/12	1	

Item	Item no.	Designation	Specification	Units	Spare part Recommendation
85	400263	CABLE SCREW FITTING	PG 16, PA	1	
88	400289	SLEEVE	DA 140/200/30	2	
89	603379	ECCENTRIC STOP		1	
90	1003918	Plate	100x70x10	1	
91	402220	TENSION RELEASE		1	
91.1	300124	HEXAGON HEAD SCREW	DIN 933 8x20 VZ	1	
91.2	300263	DISC	DIN 7349 10.5 VZ.	3	
91.3	300729	BODY WASHER	8.4x38x1.5 VZ	1	
91.4	300834	LOCKING HEXAGON NUT	BIW V-SHAPE 8.0 VZ	1	
92	201125	PIPE CLAMP		1	
93	200845	CABLE CLIP		2	
94	1002134	PROTECTION PANEL		1	
95	402083	SPACER PIN HEX ST./VZ	M6X40 SW 10	1	
96	300273	PROTECTION PANEL		1	
97	1002136	SPACER PIN HEX ST./VZ	M6X40 SW 10	1	
98	300388	HEXAGON NUT	DIN 934 8.0 galvanised	1	
99	300396	PLASTIC STRIP		1	



Note

To prevent incorrect deliveries, when ordering spare parts, indicate the complete model designation, year of manufacture and the machine number!

Technical changes may be made!

We make it explicitly clear that parts not supplied by us are also not tested and released by us. The installation and use of such products can therefore, in certain conditions, modify your equipment negatively and thus affect safety. For damages caused by the use of non-original parts and accessories, there is no liability!

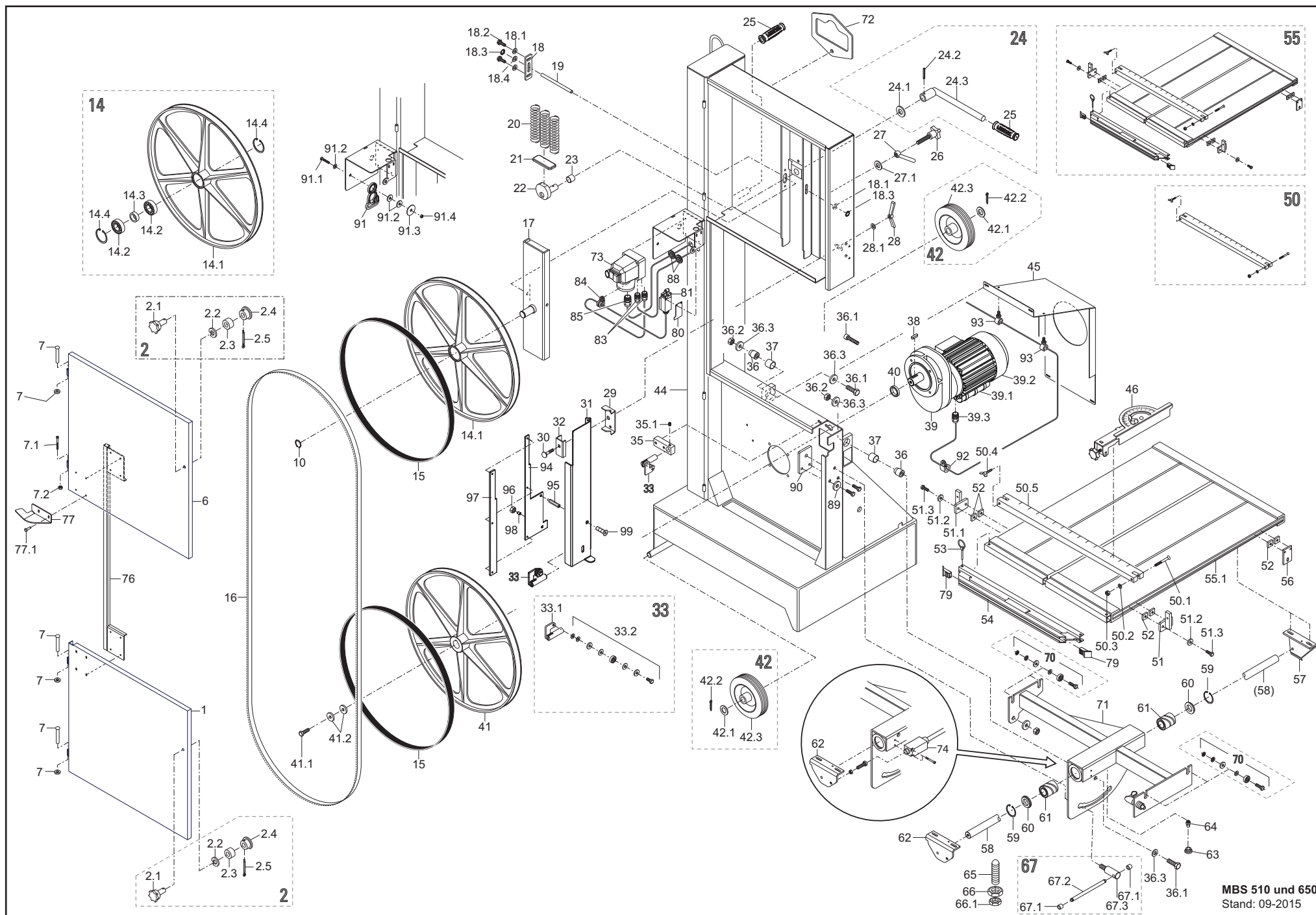

11. SPARE PARTS LIST MBS 760

Item	Item no.	Designation	Specification	Units	Spare part Recommendation
2	680934	DOOR LOCK, ASSY			X
2.1		DOOR LOCK, ASSY		1	
2.2		SPRING WASHER	DIN 137 8,	1	
2.3		SPRING WASHER	PLASTIC PE	1	
2.4		DOOR LOCK	16x8.2x6	1	
2.5		SPLINT	DIN 94 3.2x36	1	
3	680851	DOOR LOCK, ASSY			X
3.1		DOOR LOCK, ASSY. W/ STAR HANDLE		1	
3.2		SPRING WASHER	DIN 137 8.4	1	
3.3		SPACER SLEEVE, PLASTIC	PLASTIC PE	1	
3.4		DOOR LOCK	16x8.2x6	1	
3.5		SPLINT	DIN 94 3.2x36	1	
18	680240	WHEEL, TOP, ASSY.			X
18.1		WHEEL, TOP	D=550	1	
18.2		BALL BEARING	6205 2RS B-bearing	2	
18.3		ALU WHEEL SPACER		1	
18.4		LOCKING RING	DIN 472 D = 52	2	
26	680084	CLAMPING LEVER SAW BELT, ASSY			X
26.1		SPRING PIN	ISO 8750 6x30 ROLLED	1	
26.2		STEEL WASHER	DIN 125 A 21.0.	1	
26.3		TENSIONING FIXTURE		1	
27		HANDLE	LISSMAC	1	
42	680005	BELT GUIDE, ASSY			X
42.1		BELT GUIDE		1	
42.2		SAW BELT GUIDE ROLL SINGLE WITH CARBIDE RING		1	
54	1006827	WHEEL SET CPL.			X
54.1		STEEL WASHER	DIN 125 A 21.0	3	
54.2		SPLINT	DIN 94 4.0x45	1	
54.3		SOLID RUBBER WHEEL	160x40 mm, 135 kg	1	
104	680010	CLAMPING LEVER, ASSY.			X
90		PLASTIC CAP	Ø 12 MM	2	
91		CENTRING PIN		1	
92		TOGGLE CENTRING PIN		1	
1	691237	DOORS, BOTTOM		1	
4	280223	WELD-ON BELT ROLL		3	
4.3	360129	HEXAGON SOCKET SCREW	M6x60	1	
4.4	300833	LOCK NUT	M6	1	
5	691235	DOOR CONNECTOR		1	
6	691236	DOORS, TOP		1	
7	603472	SWITCHING STOP		1	

Item	Item no.	Designation	Specification	Units	Spare part Recommendation
7.1	300583	BLIND RIVET ALU/STEEL	5x12 FLAT ROUND HEAD	1	
10	799554	CARBIDE TIPPED SAW BELT	MBS 756 4.566x27	1	X
11	204801	RUBBER RING		2	X
12	603417	WHEEL, BOTTOM		1	
12.1	300127	SAFETY SCREW	SK 10x40	1	
12.2	300177	STEEL WASHER	DIN 125 A 10.5	1	
12.3	300344	STEEL WASHER FOR WOOD CONNECTION	DIN 440 11.0	1	
13	603418	SPACER MOTOR		1	
14	300020	PARALLEL KEY	DIN 6885 A 8x7x28	1	
15	400399	GEAR MOTOR	220 V	1	
15.1	460606	CABLE SCREW FITTING	PG 16	1	
16	603420	MOTOR GUIDE PLATE		1	
17	300119	LOCKING RING	DIN 471 D = 25	1	
19	690013	CLAMPING ELEMENT		1	
20	680106	CLAMPING PIN+CLAMPING WASHER		1	
21	603055	CLAMPING PIECE		1	
21.1	300237	STEEL WASHER	DIN 9021 8.4	4	
21.2	300128	SAFETY SCREW	SK 8x12	2	
21.3	300140	CLAMPING WASHER		2	
22	203020	PRESSURE SPRING	150*30*6.5 MM 16.5 WD.	3	
23	603056	PRESSURE PLATE SPRING		1	
24	690033	ECCENTRIC		1	
25	201575	CYLINDER BUSH, PLASTIC		1	
28	203012	STAR KNOB		1	
28.2	300166	STEEL WASHER	N 125 A 13.0	1	
28.3	300632	HEXAGONAL NUT WITH CLAMPING PART	DIN 982 12.0	1	
29	203024	CONICAL KNOB	DIN 99 M12	1	
32	603322	CRANE EYE		1	
34	202574	CLAMPING NUT, DUAL ARM	M8	1	
34.1	300237	STEEL WASHER	DIN 9021 8.4	1	
35	603309	CLAMPING RAIL		1	
36	1005618	HAND PROTECTION, ASSY.		1	
37	603311	CLAMPING PLATE		1	
38	300556	CARRIAGE BOLT	DIN 603 8x45	1	
43	603061	BELT GUIDE HOLDER		1	
43.1	300388	SET SCREW	DIN 916 M 8x16	1	
44	1006829	FRAME		1	
45	201559	GALVANIZED SUPPORT WHEEL		1	
46	200324	CHAIN C. LINK	DIN 5685 26x3 mm, galvanised	1	
47	280042	HANDLE	LISSMAC	2	
48	400289	SLEEVE		2	
49	603471	LIMIT SWITCH PLATE, TOP		1	
50	402212	END SWITCH		1	
51	402298	SWITCH		1	X
51.1	400485	CABLE SCREW FITTING		1	
51.2	400461	CABLE SCREW FITTING		2	
52	200377	PIPE CLAMP	RK 22	2	
55	690302	THREADED CRANK		2	
56	691241	SUPPORT FOOT		2	
57	603351	THREADED NUT		2	
58	603452	SLEEVE		2	
59	603236	DISC		2	
60.1	606113	SWIVEL PIN		2	
60.2	300847	HEXAGON HEAD SCREW	DIN 931 12x50	2	

Item	Item no.	Designation	Specification	Units	Spare part Recommendation
60.3	300166	STEEL WASHER	DIN 125 A 13.0	2	
60.4	300559	LOCK NUT	BIW V-FORM 12.0	2	
61	201576	CYLINDER BUSH, PLASTIC		2	
62	691234	CRANE HOLDER		1	
63	201125	PIPE CLAMP W/ RUBBER PROFILE	TYPE 1 B=12 mm	1	
63.1	200845	CABLE CLIP	99 X 2.5	2	
64	400132	FLEXIBLE RUBBER LINE	0.400 m	-	
66	400470	FLEXIBLE RUBBER LINE	2,100 m	-	
67	400132	FLEXIBLE RUBBER LINE	3,000 m	-	
68.1	402220	TENSION RELEASE		1	
68.2	300124	HEXAGON HEAD SCREW	DIN 933 8x20	1	
68.3	300125	STEEL WASHER	DIN 125 A 8.4	1	
68.4	300263	STEEL WASHER	DIN 7349 10.5	2	
68.5	300729	BODY WASHER	8.3x38x1.5	1	
68.6	300834	LOCK NUT	BIW V-FORM 8.0	1	
69	280199	OPEN ENDED SPANNER	DIN 894 SW 13	1	
70	200237	HANDLE, PLASTIC, BLACK		2	
71	1002425	PINCH PROTECTION , FRONT LEFT		1	
72	1002428	PINCH PROTECTION, FRONT RIGHT		1	
73	300426	SPRING PIN	ISO 8752 6x30	6	
74	603422	LEVER, LEFT		3	
75	603425	CONNECTION		1	
75.1	300342	HEXAGON HEAD SCREW	DIN 933 10x25	5	
76	603423	LEVER W/ FIXTURE		2	
77	603426	CONNECTING BRIDGE		1	
77.1	300193	HEXAGON HEAD SCREW	DIN 933 10x35	2	
78	603461	CONNECTING BRACE		1	
79	300342	HEXAGON HEAD SCREW	DIN 933 10x25	2	
80	202736	FOLD-DOWN HANDLE W/THREADS		1	X
80.1	201822	HANDLE	LISSMAC	1	
81	1006740	HOLDER HANDLE		1	
82	603098	GUIDE SHAFT		2	
83	300102	LOCKING RING	52	4	X
84	201694	WIPER RING	AS 40-52-5/8	4	X
85	280065	BALL SLEEVE		4	X
86	691242	ROCKER		1	
87	280026	BALL BEARING	6200-2RS	2	
87.1	300193	HEXAGON HEAD SCREW		2	
87.2	300177	STEEL WASHER	DIN 125 A 10.5	2	
87.3	300263	STEEL WASHER	DIN 7349 10.5	2	
87.4	300202	SCHNORR SAFETY WASHER	10.0	2	
87.5	300146	HEXAGON NUT	DIN 934 10.0	2	
88	300040	LUBRICATION NIPPLE	DIN 71412 10x1	1	
89	400053	END SWITCH		1	
93	1006810	LEVER HOLDER		1	
94	1004248	STIFFENING PLATE, REAR		1	
95	1002405	COVER REAR		1	
96	1004082	LATCH PLATE		1	
97	1002409	STIFFENING PLATE, FRONT		1	
98	1002411	COVER, FRONT LEFT		1	
99	1002412	COVER, FRONT RIGHT		1	
100	1006809	BRIDGE ANCHOR		2	
101	1006808	LATCH PLATE		1	
105.1	691239	HOLDER, RIGHT		1	

Item	Item no.	Designation	Specification	Units	Spare part Recommendation
105.2	300125	STEEL WASHER	DIN 125 A 8.4	2	
105.3	300046	SAFETY SCREW	SK 8x16	2	
106	300130	WING SCREW	DIN 316 6x25	1	
107	603462	SCALE STOP		1	X
108	680025	SIDE STOP, ASSY.		1	X
110	603444	STOP		1	
112	1004073	HOLDER SHAFT		12	
113	1002413	ECCENTRIC		12	
114	300840	SPRING PIN	ISO 8748 6x24 SPIRAL	12	
115	204737	LOAD BEARING ROLLER		6	
116	603442	SIDE MEMBER		8	
118.1	691240	HOLDER, LEFT		1	
118.2	300125	STEEL WASHER	DIN 125 A 8.4	2	
118.3	300046	SAFETY SCREW		2	
123	1002134	PROTECTION PANEL		1	
124	402083	SPACER PIN HEX ST./VZ	M6x40 SW 10	1	
125	300273	HEXAGON NUT	DIN 934 8.0	1	
126	1002136	PLASTIC STRIP		1	
127	300388	SET SCREW	DIN 916 M8x16	1	
128	300296	COUNTERSUNK HEAD SCREW W/ ALLEN KEY	DIN 7991 6x16	1	
129	300741	RETAINING RING	DIN 471 D = 10	2	
130	1008642	SCRAPER		1	
131	1008656	STIFFENING		1	
132	1008628	SHAFT		1	
133	1008643	SCRAPER		1	
134	280026	BALL BEARING	6200-2RS	2	
135	1005562	ROLLER		1	
136	300046	SAFETY SCREW	SK 8x16	8	
137	1008521	SHINE		1	
138	1008630	ANGLE		2	
139	300166	WASHER - STEEL	DIN 125 A 13,0	2	
140	360155	HEXAGONAL SCREW	DIN 933 12x100	1	
141	1008525	TELESCOPE OUTER TUBE		1	
142	300326	HEXAGON NUT	DIN 936 12,0	2	
143	1008526	TELESCOPE INNER TUBE		1	
144	300080	HEXAGON NUT	DIN 934 12,0	1	
145	300324	HEXAGONAL SCREW	DIN 933 12x60	1	
146	300474	SPLIT PIN	DIN 94 5,0x32	1	



Note

To prevent incorrect deliveries, when ordering spare parts, indicate the complete model designation, year of manufacture and the machine number!

Technical changes may be made!

We make it explicitly clear that parts not supplied by us are also not tested and released by us. The installation and use of such products can therefore, in certain conditions, modify your equipment negatively and thus affect safety. For damages caused by the use of non-original parts and accessories, there is no liability!

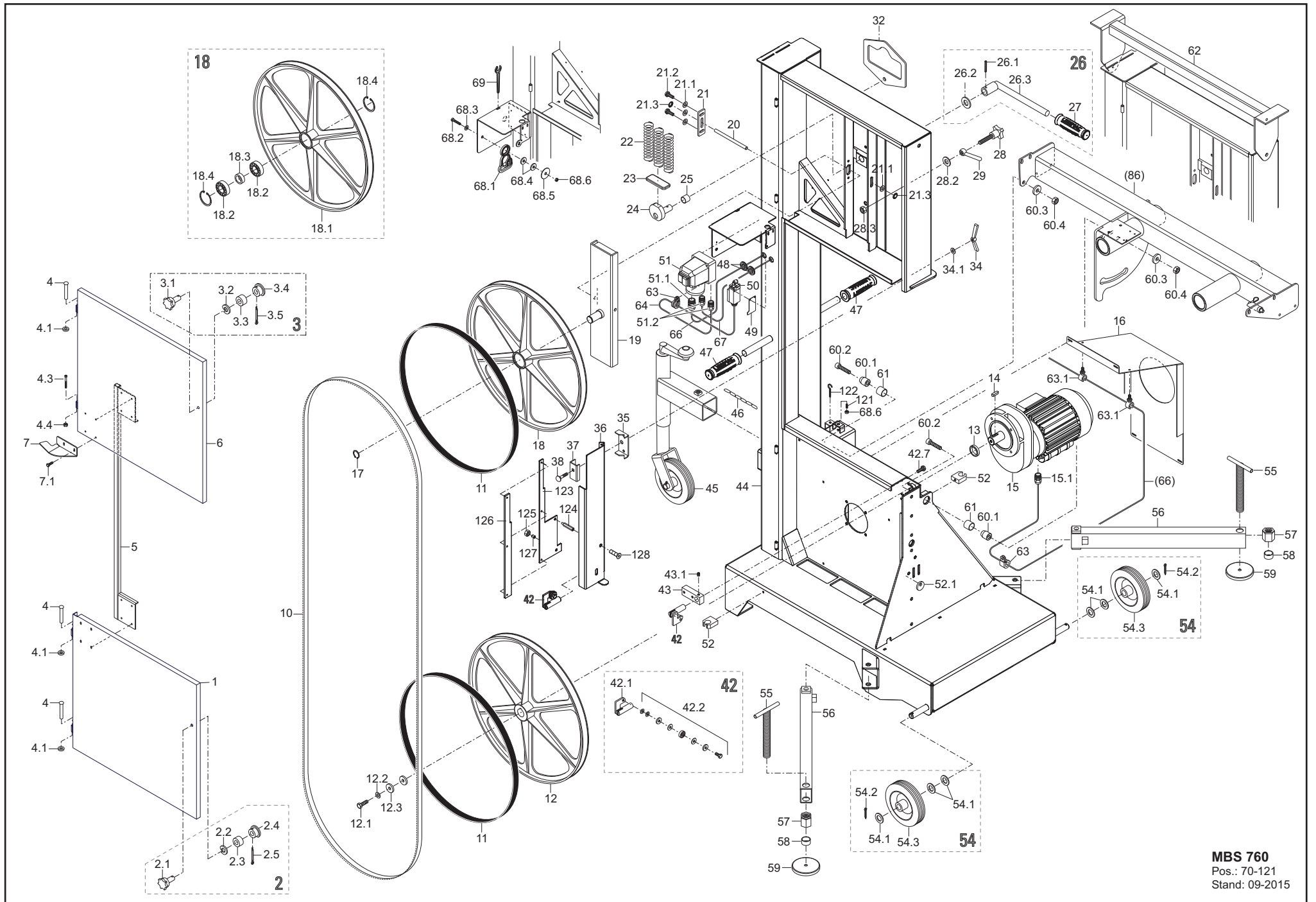

MBS 760
 Pos.: 70-121
 Stand: 09-2015

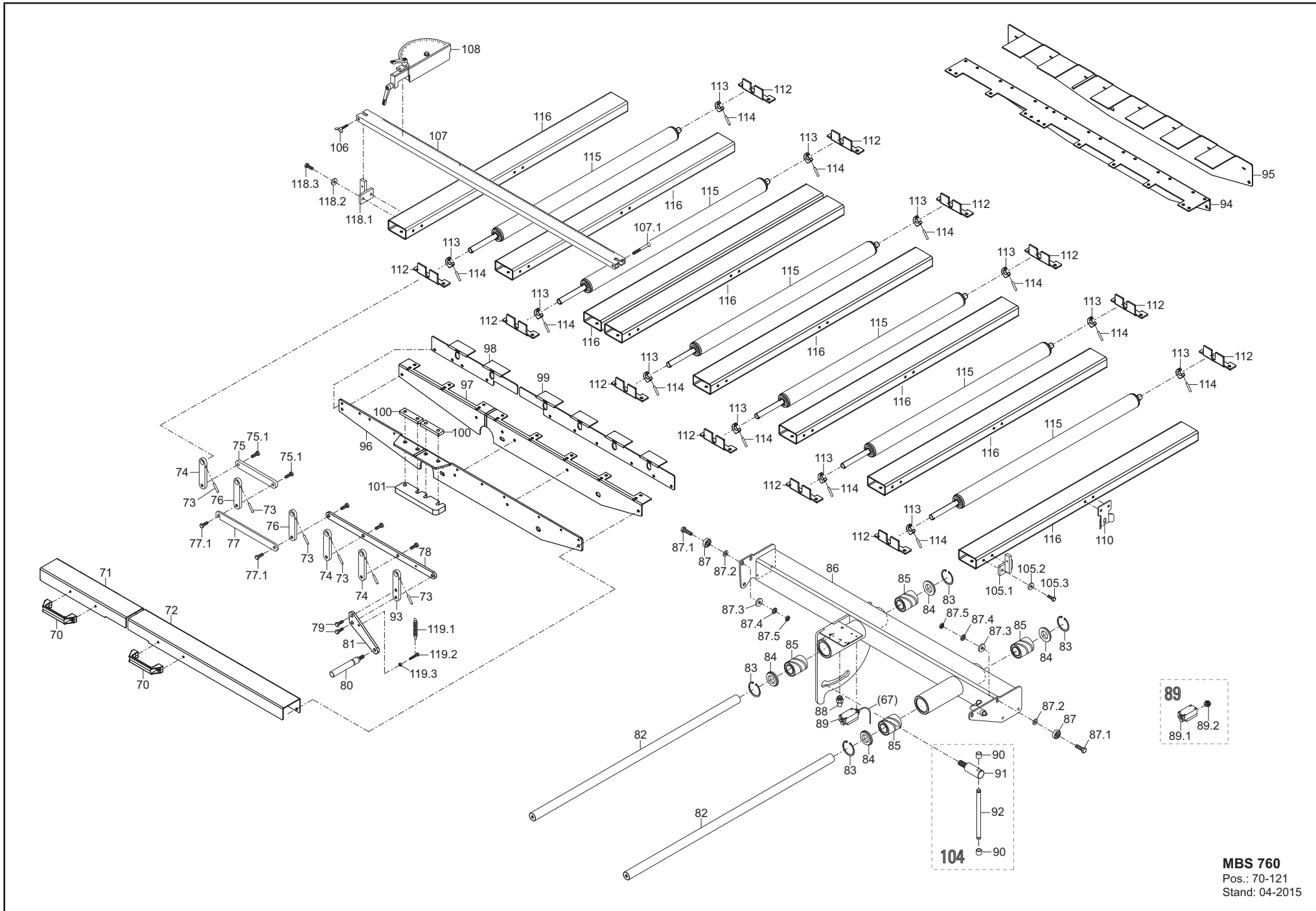

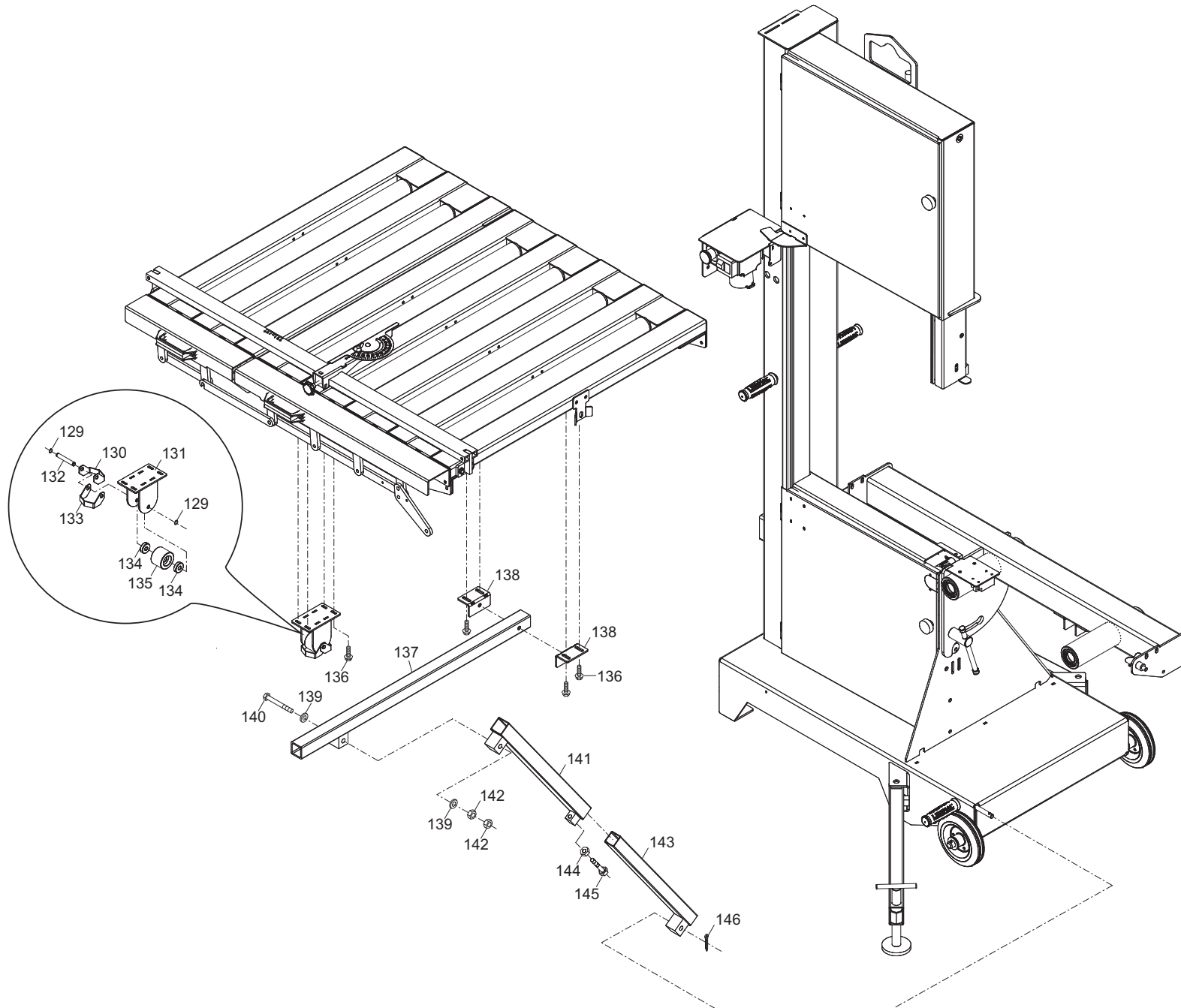

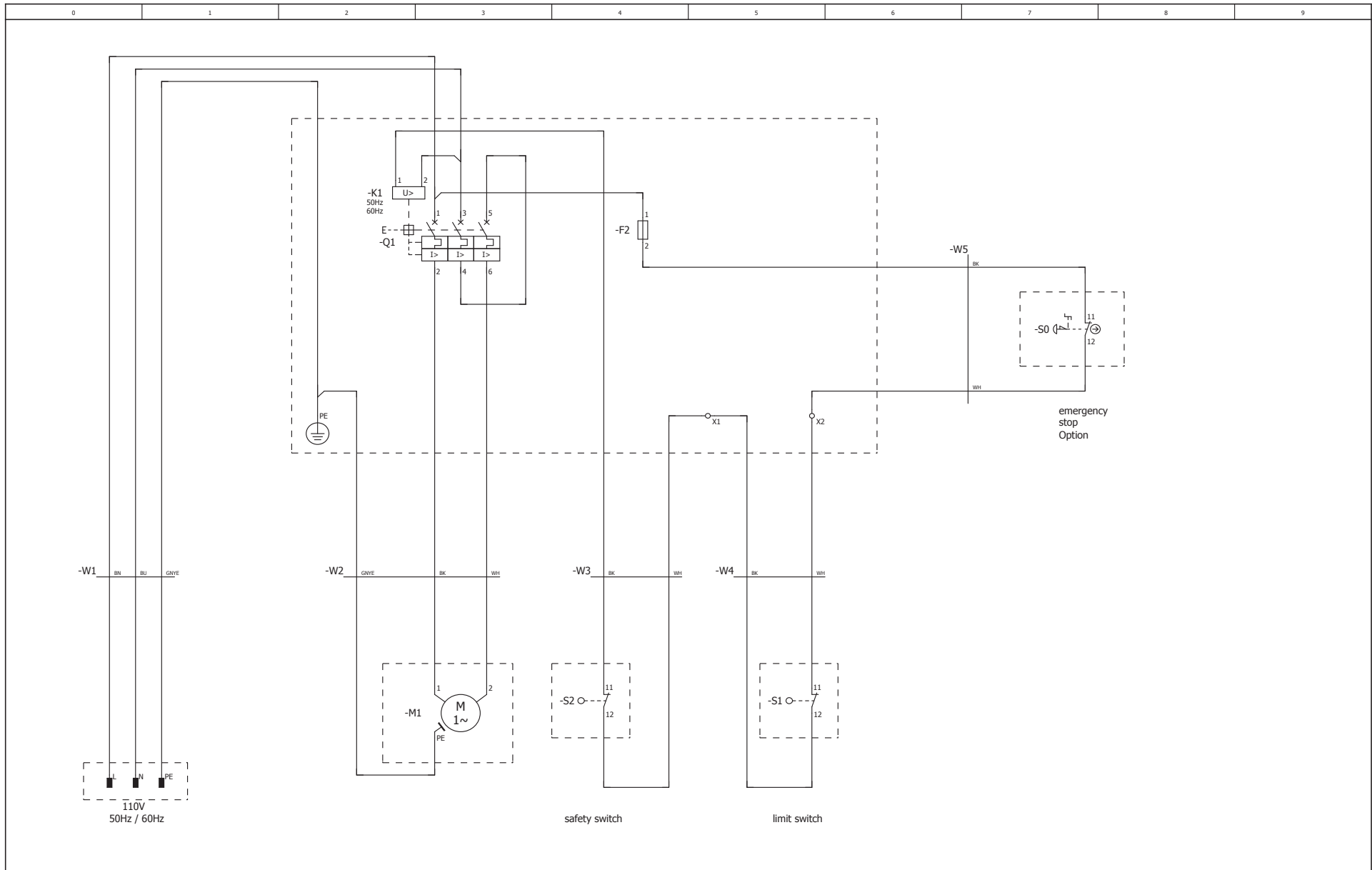

		Datum	18.03.2014					=
		Bearb.	Pfender	MBS 110V				+
		Gepr.						Blatt 1
Änderung	Datum	Name	Urspr	Ersatz von	Ersetzt durch			Blatt 1

LISSMAC

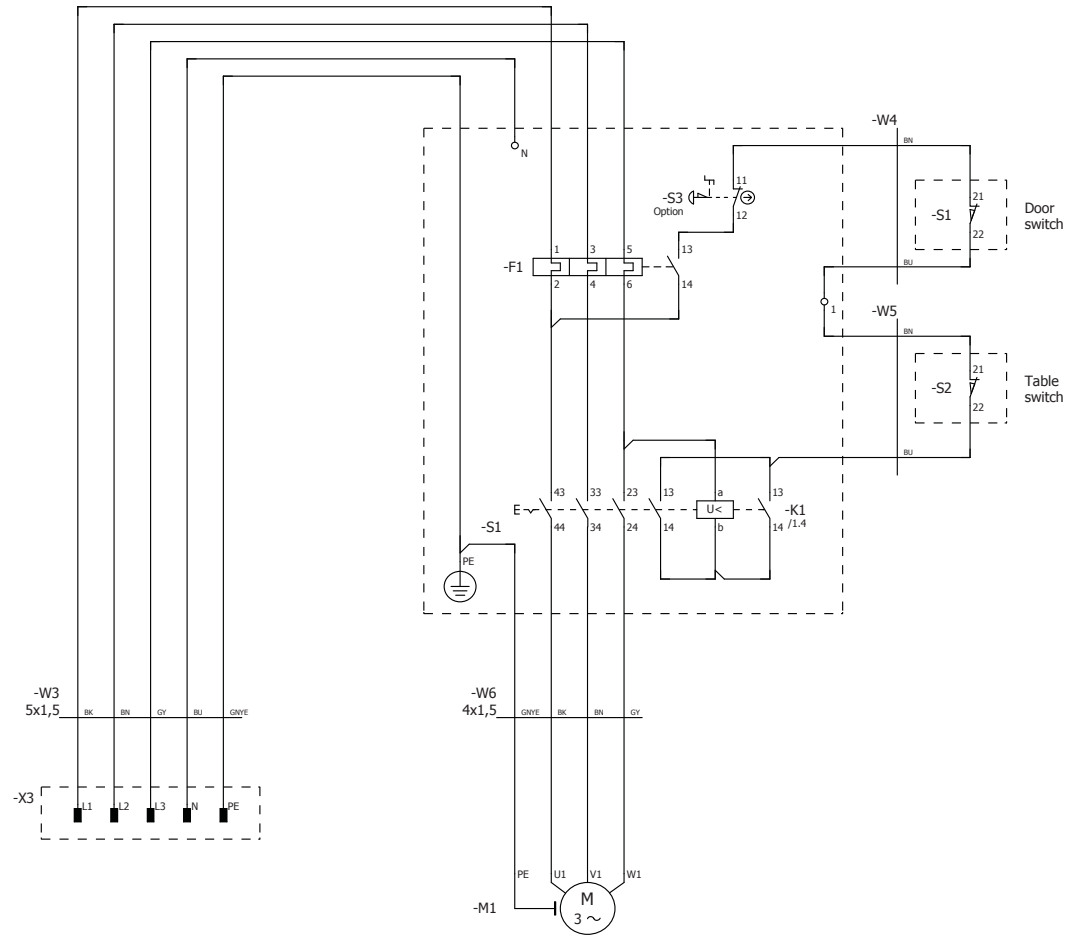

1		Datum	17.03.2014	MBS 400V	LISSMAC	=	Blatt 2				
		Bearb.	Pfender					Ersatz von	Ersetzt durch	+	Blatt 2
		Gepr									
Änderung	Datum	Name	Urspr								



This EC Declaration of Conformity is valid for the following machine:
LISSMAC Cellular concrete band saws MBS 510, MBS 650 and 760.

This declaration relates exclusively to the machine in the state in which it was placed on the market, and excludes components which are added and/or operations carried out subsequently by the final user. It is confirmed that the machine conforms to the relevant provisions of Directive 2006/42/EC.

Manufacturer:

LISSMAC Maschinenbau GmbH
Lanzstrasse 4
D-88410 Bad Wurzach

The technical documentation retained by
LISSMAC Maschinenbau GmbH, D-88410 Bad Wurzach

Machine description:

The LISSMAC cellular concrete band saw is designed exclusively for cutting large-sized masonry stones. Cutting includes masonry stones made of porous concrete and perforated bricks in dry cut within the adjustable operating range.

Cutting wood, metal, plastic or other types of stone is prohibited!

Stone cutting saw	MBS 510	MBS 650	MBS 760
Cutting height series/ max.	515 mm	650 mm	760 mm
Cut length	700 mm	700 mm	700 mm
Saw belt length	3750 mm	4020 mm	4566 mm
Drive motor	Elektromotor		
Power	1,1 kW / 1,5 kW		1,1 kw
Voltage	110V / 230V / 400V		
Guaranteed noise power level L _{WA} :	101,8 dB (A)		
Measured noise level L _{pA} :	83,8 dB (A)		
Table loading capacity	50 kg		200
Weight	173 kg	175 kg	367 kg

Harmonised standards:

EN 12418:2000+A1:2009
EN ISO 12100:2011-03
EN 60204-1; VDE 0113-1:2007-06

Legally binding representative:

LISSMAC Maschinenbau GmbH
Lanzstrasse 4
D-88410 Bad Wurzach
Tel.: +49 (0) 7564 / 307 - 0
Fax: +49 (0) 7564 / 307 - 500
Mail: lissmac@lissmac.com
www.lissmac.com

Bad Wurzach, dated 28.11.2014



by proxy Marcel Hofstetter
(Head of Development Construction Technology)

