

TB215R



# SHORT TAIL SWING EXCAVATOR

**TAKEUCHI**  
Japanese for reliability

# TB215R short tail swing mini excavator

Takeuchi introduce the new TB215R, a 1.5 tonne short tail swing mini excavator. The TB215R offers the most compact mini excavator in the Takeuchi range and gets the mini digger into the tightest spaces. An excellent alternative for tool hire, utilities, light landscaping and jobbing builders.

A very compact machine, just 720mm slew radius, the TB215R is a powerful lightweight option.

Designed for maximum dig depth 2190mm and dump height 2400mm the new TB215R has excellent working ranges and a powerful engine for a 1.5 tonne machine weight class.



## **ROBUST FOR SITE**

The top mounted hydraulic boom cylinder and internally routed hoses helps avoid potential site damage.



## **PROVEN EXPANDABLE TRACK FRAME**

A unique expanding track frame adjusts from 980 to 1300mm getting access in narrow openings. Added track width gives greater operating stability, as proven on TB016 & TB216. The TB215R has double flanged rollers for reliable track retention.

The TB215R is a very well protected mini digger built for the toughest site conditions.

Operators enjoy the smooth operation and powerful digging force from a compact portable machine. With a maximum dig depth up to 2190mm and dump height of 2400mm alongside a maximum reach at ground level as far as 3815mm the TB215R really does outperform for its compact size.

Precise proportional control valves achieve the smoothest digging operation vital in critical dig sites working around live cables and pipes.

A 1.5 tonne short tail swing is an excellent alternative when space is limited for all types of application - landscaping, utilities, groundworks and street works.

**With a reputation for reliability, Japanese build quality makes all the difference.**



### REDUCED TAIL SWING

Offering excellent accessibility the TB215R with just 720mm slew radius and a compact rear side, will work close up to walls without any potential machine damage. The TB215R has just 70mm overhang at 90° to extended track.



### EASY ACCESS & MAINTENANCE

Service door for easy radiator access, fuel filter and maintenance. A conveniently placed bracket for grease gun at the front of the canopy and the toolbox area behind the seat. The battery is positioned below the seat.



### PERFORMANCE

- Proven strong track frame design offers excellent balance and stability with a longer than average track frame (1520mm).
- Simultaneous operation of swing and digging function, and two speed travel gives fast cycle times.
- Auxiliary hoses are easy to attach and well positioned high up the dipper arm for added protection.

### OPERATION

- Added offset position RH 70° and LH 50°.
- Cushioned main boom and swing cylinders for smooth operation.
- Boom and canopy mounted work lights give options for all types of working conditions.
- Well positioned enhanced VDU - warning indicators, rpm, hour meter, fuel, battery charge, temperature, oil pressure and maintenance alerts.

### SAFETY & SERVICE

- Enhanced 100% steel wraparound frame protects key components.
- Standard service features include; Safe Drain engine oil system, hydraulic and fuel gauges in cab and at filler, fuel drain system, hydraulic oil cooler, maintenance free battery.

### OPTIONS

- TKB52-S Breaker
- Quick Hitch
- Bucket sizes from 150-1000mm



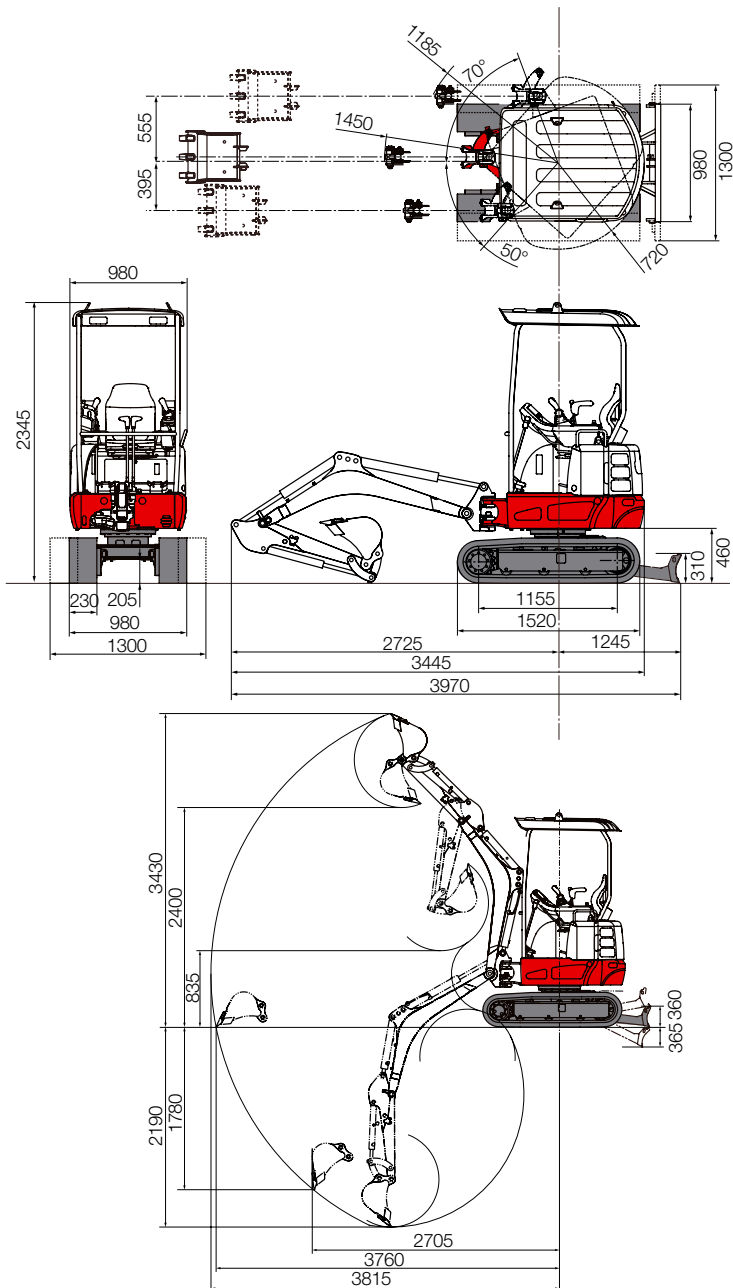

**For more information locally**  
call us direct, or contact:

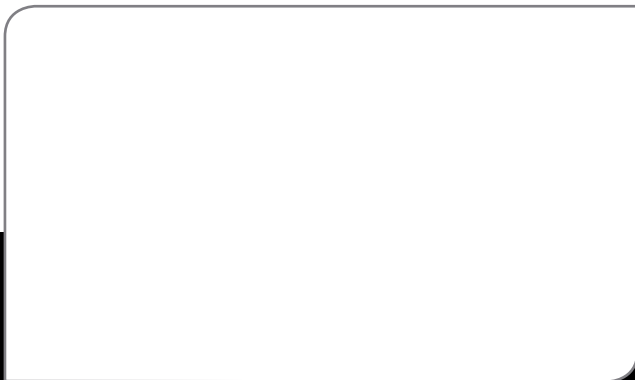

**Takeuchi Mfg (UK) Ltd**, Unit E2B Kingsway Business Park,  
John Boyd Dunlop Drive, Rochdale, Lancashire OL16 4NG  
Tel: 01706 657 722 Fax: 01706 657 744

**Southern Depot** at 20 Colthrop Business Park  
Colthrop Lane, Thatcham, Newbury, Berks RG19 4NB  
Tel: 01635 877 196 Fax: 01635 877 195

[www.takeuchi-mfg.co.uk](http://www.takeuchi-mfg.co.uk) Email: [sales@takeuchi-mfg.co.uk](mailto:sales@takeuchi-mfg.co.uk)

## TB215R

Standard UK Specification - Long Dipper

Engine	
Make	YANMAR
Model	3TNV 70
Rated Output (kW)/rpm	11.5/2400
Maximum Torque (Nm)	52.7
Cylinders	3
Displacement (cc)	854
Electrical System	12V

Dimensions & Weight	
Operating Weight inclusive of bucket and fuel: cab/canopy (kg)	1600
Overall Length (mm)	3445
Width cab/canopy (mm)	980
with extended track (mm)	1300
Height cab/canopy (mm)	2345
Ground Clearance (mm)	205
Min. Front Swing Radius (mm)	1450
Tail Swing Radius (mm)	720
Dozer Blade (W x H) (mm)	900/1300 x 310

Operating Information	
Max Digging Depth (mm)	2190
Max Dump Height (mm)	2400
Max Reach at Ground Level (mm)	3815
Max Vertical Digging Depth (mm)	1780
Max Bucket Digging Force (kN)	14
Max Arm Digging Force (kN)	9.5

Hydraulic System	
Set Pressure (bar)	210
Pump Type	Variable
Hydraulic Flow Aux Port (l/min)	33

Swing System	
Boom Swing Angle (R/L)	75°/50°
Slew Speed (rpm)	9.2
Slew Motor	Trachoid Gear

Undercarriage	
Traction Motor	Piston
Traction Drive	Epicyclic Gearing
Traction Brake	Friction Brake
Traction Width (mm)	230
Ground Contact Length (mm)	1155
Ground Pressure (kpa)	26.2
Travel Speed (km/h)	2.2-4.2
Maximum Gradeability	30°

Capacities	
Hydraulic System (l)	24
Fuel Tank (l)	22
Engine Lubrication (l)	4.3
Cooling System (l)	3.9

All dimensions unless otherwise stated are in millimetres.

07/2014

Takeuchi machines come with a 2 year/2000 hours warranty as standard. Warranty exceptions to 1 year; fuel injection systems, electrical components, paint work.

In accordance with our established policy of constant improvement, we reserve the right to amend these specifications at any time without notice. Photographs shown may feature non-standard equipment.

**TAKEUCHI**  
Japanese for reliability